

Signal Analysis Measurement Guide

Agilent Technologies EMC Series Analyzers

This guide documents firmware revision A.08.xx

This manual provides documentation for the following instruments:

E7401A (9 kHz- 1.5 GHz)

E7402A (9 kHz - 3.0 GHz)

E7403A (9 kHz - 6.7 GHz)

E7404A (9 kHz - 13.2 GHz)

E7405A (9 kHz - 26.5 GHz)



Manufacturing Part Number: E7401-90049

Supersedes: E7401-90025

Printed in USA

December 2001

© Copyright 2001 Agilent Technologies

Notice

The information contained in this document is subject to change without notice.

Agilent Technologies makes no warranty of any kind with regard to this material, including but not limited to, the implied warranties of merchantability and fitness for a particular purpose. Agilent Technologies shall not be liable for errors contained herein or for incidental or consequential damages in connection with the furnishing, performance, or use of this material.

Safety Information

The following safety symbols are used throughout this manual. Familiarize yourself with the symbols and their meaning before operating this instrument.

WARNING

***Warning* denotes a hazard. It calls attention to a procedure which, if not correctly performed or adhered to, could result in injury or loss of life. Do not proceed beyond a warning note until the indicated conditions are fully understood and met.**

CAUTION

Caution denotes a hazard. It calls attention to a procedure that, if not correctly performed or adhered to, could result in damage to or destruction of the instrument. Do not proceed beyond a caution sign until the indicated conditions are fully understood and met.

NOTE

Note calls out special information for the user's attention. It provides operational information or additional instructions of which the user should be aware.



The instruction documentation symbol. The product is marked with this symbol when it is necessary for the user to refer to the instructions in the documentation.



This symbol is used to mark the on position of the power line switch.



This symbol is used to mark the standby position of the power line switch.



This symbol indicates that the input power required is AC.

WARNING **This is a Safety Class 1 Product (provided with a protective earth ground incorporated in the power cord). The mains plug shall be inserted only in a socket outlet provided with a protected earth contact. Any interruption of the protective conductor inside or outside of the product is likely to make the product dangerous. Intentional interruption is prohibited.**

WARNING **No operator serviceable parts inside. Refer servicing to qualified personnel. To prevent electrical shock do not remove covers.**

WARNING **If this product is not used as specified, the protection provided by the equipment could be impaired. This product must be used in a normal condition (in which all means for protection are intact) only.**

CAUTION Always use the three-prong AC power cord supplied with this product. Failure to ensure adequate grounding may cause product damage.

Warranty

This Agilent Technologies instrument product is warranted against defects in material and workmanship for a period of three years from date of shipment. During the warranty period, Agilent Technologies will, at its option, either repair or replace products which prove to be defective.

For warranty service or repair, this product must be returned to a service facility designated by Agilent Technologies. Buyer shall prepay shipping charges to Agilent Technologies and Agilent Technologies shall pay shipping charges to return the product to Buyer. However, Buyer shall pay all shipping charges, duties, and taxes for products returned to Agilent Technologies from another country.

Agilent Technologies warrants that its software and firmware designated by Agilent Technologies for use with an instrument will execute its programming instructions when properly installed on that instrument. Agilent Technologies does not warrant that the operation of the instrument, or software, or firmware will be uninterrupted or error-free.

LIMITATION OF WARRANTY

The foregoing warranty shall not apply to defects resulting from improper or inadequate maintenance by Buyer, Buyer-supplied software or interfacing, unauthorized modification or misuse, operation outside of the environmental specifications for the product, or improper site preparation or maintenance.

NO OTHER WARRANTY IS EXPRESSED OR IMPLIED. AGILENT TECHNOLOGIES SPECIFICALLY DISCLAIMS THE IMPLIED WARRANTIES OF MERCHANTABILITY AND FITNESS FOR A PARTICULAR PURPOSE.

Should Agilent have a negotiated contract with the User and should any of the contract terms conflict with these terms, the contract terms shall control.

EXCLUSIVE REMEDIES

THE REMEDIES PROVIDED HEREIN ARE BUYER'S SOLE AND EXCLUSIVE REMEDIES. AGILENT TECHNOLOGIES SHALL NOT BE LIABLE FOR ANY DIRECT, INDIRECT, SPECIAL, INCIDENTAL, OR CONSEQUENTIAL DAMAGES, WHETHER BASED ON CONTRACT, TORT, OR ANY OTHER LEGAL THEORY.

Where to Find the Latest Information

Documentation is updated periodically. For the latest information about Agilent Technologies EMC Analyzers, including firmware upgrades and application information, please visit the following Internet URL:

<http://www.agilent.com/find/emc>

Microsoft® is a U.S. registered trademark of Microsoft Corporation.

Contents

1. Making Basic Measurements

What is in This Chapter	8
Test Equipment	9
Comparing Signals	10
Signal Comparison Example 1:	10
Signal Comparison Example 2:	12
Resolving Signals of Equal Amplitude	14
Resolving Signals Example:	15
Resolving Small Signals Hidden by Large Signals	18
Resolving Signals Example:	19
Making Better Frequency Measurements	22
Better Frequency Measurement Example:	22
Decreasing the Frequency Span Around the Signal	24
Decreasing the Frequency Span Example:	24
Tracking Drifting Signals	27
Tracking Signal Drift Example 1:	27
Tracking Signal Drift Example 2:	30
Measuring Low Level Signals	34
Measuring Low Level Signals Example 1:	34
Measuring Low Level Signals Example 2:	36
Measuring Low Level Signals Example 3:	37
Measuring Low Level Signals Example 4:	39
Identifying Distortion Products	42
Distortion from the Analyzer	42
Identifying Analyzer Generated Distortion Example:	42
Third-Order Intermodulation Distortion	45
Identifying TOI Distortion Example:	45
Measuring Signal-to-Noise	49
Signal-to-Noise Measurement Example:	49
Making Noise Measurements	51
Noise Measurement Example 1:	51
Noise Measurement Example 2:	56
Noise Measurement Example 3:	56
Demodulating AM Signals (Using the Analyzer As a Fixed Tuned Receiver)	59
Demodulating an AM Signal Example 1:	59
Demodulating FM Signals	65
Demodulating a FM Signal Example:	65

2. Making Complex Measurements

What's in This Chapter	70
Required Test Equipment	70
Making Stimulus Response Measurements	71
What Are Stimulus Response Measurements?	71
Using An Analyzer With A Tracking Generator	71
Stepping Through a Transmission Measurement	71

Contents

Tracking Generator Unleveled Condition	76
Measuring Device Bandwidth	76
Measuring Stop Band Attenuation Using Log Sweep	79
Making a Reflection Calibration Measurement	84
Example:	84
Reflection Calibration	85
Measuring the Return Loss	86
Demodulating and Listening to an AM Signal	88
Demodulating and Listening to an AM Signal	
Example 1:	88
Demodulating and Listening to an AM Signal	
Example 2:	89

1 Making Basic Measurements

What is in This Chapter

This chapter demonstrates basic analyzer measurements with examples of typical measurements; each measurement focuses on different functions. The measurement procedures covered in this chapter are listed below.

- “Comparing Signals” on page 10.
- “Resolving Signals of Equal Amplitude” on page 14.
- “Resolving Small Signals Hidden by Large Signals” on page 18.
- “Making Better Frequency Measurements” on page 22.
- “Decreasing the Frequency Span Around the Signal” on page 24.
- “Tracking Drifting Signals” on page 27.
- “Measuring Low Level Signals” on page 34.
- “Identifying Distortion Products” on page 42.
- “Measuring Signal-to-Noise” on page 49.
- “Making Noise Measurements” on page 51.
- “Demodulating AM Signals (Using the Analyzer As a Fixed Tuned Receiver)” on page 59.
- “Demodulating FM Signals” on page 65.

To find descriptions of specific analyzer functions, refer to the Agilent Technologies EMC Analyzers User’s Guide.

Test Equipment

Test Equipment	Specifications	Recommended Model
Signal Sources		
Signal Generator (2)	0.25 MHz to 4.0 GHz Ext Ref Input	E4433B or E443XB series
Adapters		
Type-N (m) to BNC (f) (3)		1250-0780
Termination, 50 Ω Type-N (m)		908A
Cables		
(3) BNC, 122-cm (48-in)		10503A
Miscellaneous		
Directional Bridge		86205A
Bandpass Filter	Center Frequency: 200 MHz Bandwidth: 10 MHz	
Lowpass Filter (2)	Cutoff Frequency: 300 MHz	0955-0455
RF Antenna		08920-61060

Comparing Signals

Using the analyzer, you can easily compare frequency and amplitude differences between signals, such as radio or television signal spectra. The analyzer delta marker function lets you compare two signals when both appear on the screen at one time or when only one appears on the screen.

Signal Comparison Example 1:

Measure the differences between two signals on the same display screen.

1. Perform a factory preset by pressing **Preset**, **Factory Preset** (if present).
2. Connect the 10 MHz REF OUT from the rear panel to the front-panel INPUT.
3. Set the center frequency to 30 MHz by pressing **FREQUENCY**, **Center Freq**, **30**, **MHz**.
4. Set the span to 50 MHz by pressing **SPAN**, **Span**, **50**, **MHz**.
5. Set the resolution bandwidth to spectrum analyzer coupling by pressing **BW/Avg**, **Res BW** (SA).
6. Set the Y-Axis Units to dBm by pressing **AMPLITUDE**, **More**, **Y-Axis Units**, **dBm**.
7. Set the reference level to 10 dBm by pressing **AMPLITUDE**, **Ref Level**, **10**, **dBm**.

The 10 MHz reference signal appears on the display.

8. Press **Peak Search** to place a marker at the highest peak on the display. (The **Next Pk Right** and **Next Pk Left** softkeys are available to move the marker from peak to peak.) The marker should be on the 10 MHz reference signal. See [Figure 1-1](#).

Figure 1-1 Placing a Marker on the 10 MHz Signal

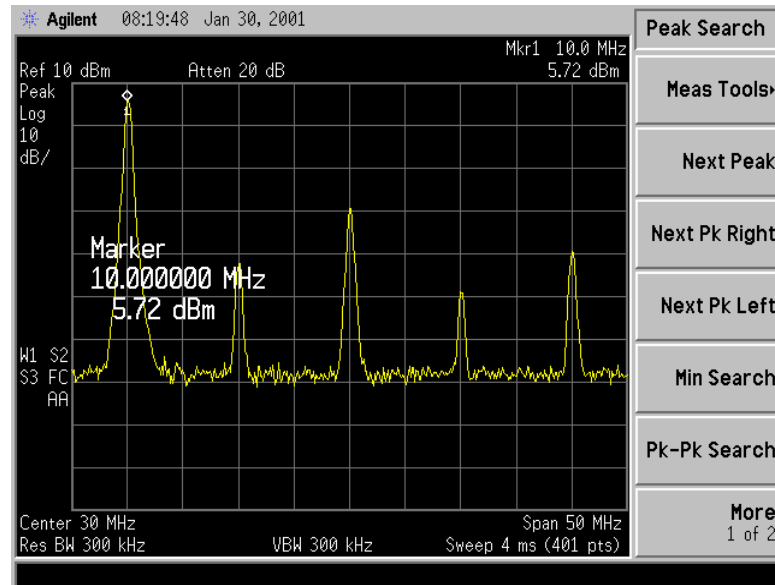

9. Press **Marker, Delta**, to activate a second marker at the position of the first marker.
10. Move the second marker to another signal peak using the front-panel knob, or by pressing **Peak Search** and then either **Next Pk Right** or **Next Pk Left**. Next peak right is shown in [Figure 1-2](#).

The amplitude and frequency difference between the markers is displayed in the active function block and in the upper right corner of the screen. See [Figure 1-2](#).
11. The resolution of the marker readings can be increased by turning on the frequency count function. For more information refer to [“Making Better Frequency Measurements” on page 22](#).
12. Press **Marker, Off** to turn the markers off.

Figure 1-2 Using the Marker Delta Function

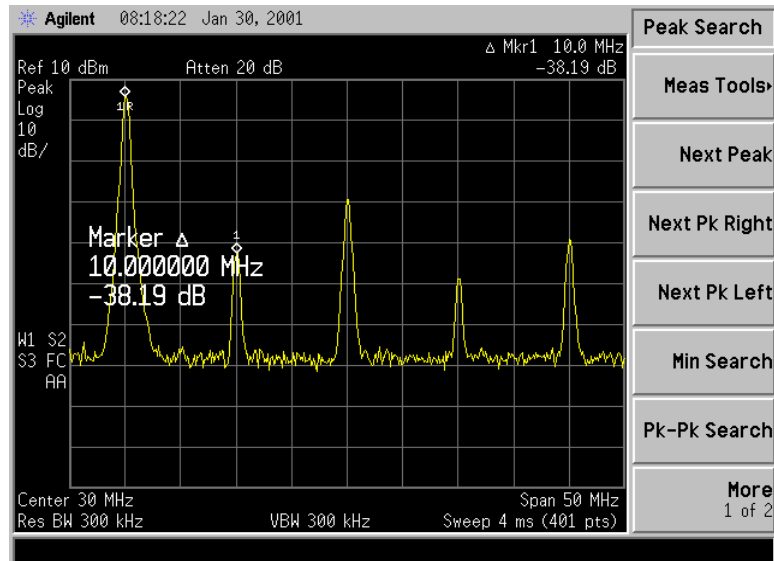

Signal Comparison Example 2:

Measure the frequency and amplitude difference between two signals that do not appear on the screen at one time. (This technique is useful for harmonic distortion tests when narrow span and narrow bandwidth are necessary to measure the low level harmonics.)

1. Perform a factory preset by pressing **Preset, Factory Preset** (if present).
2. Connect the 10 MHz REF OUT from the rear panel to the front-panel INPUT.
3. Set the center frequency to 10 MHz by pressing **FREQUENCY, Center Freq, 10, MHz**.
4. Set the span to 5 MHz by pressing **SPAN, 5, MHz**.
5. Set the resolution bandwidth to spectrum analyzer coupling by pressing **BW/Avg, Res BW (SA)**.
6. Set the Y-Axis Units to dBm by pressing **AMPLITUDE, More, Y-Axis Units, dBm**.
7. Set the reference level to 10 dBm by pressing **AMPLITUDE, Ref Level, 10, dBm**.

The 10 MHz reference signal appears on the display.

8. Press **Peak Search** to place a marker on the peak.
9. Press **Marker→, Mkr→CF Step** to set the center frequency step size equal to the frequency of the fundamental signal.

10. Press **Marker, Delta** to anchor the position of the first marker and activate a second marker.
 11. Press **FREQUENCY, Center Freq**, and the (\uparrow) key to increase the center frequency by 10 MHz. The first marker moves to the left edge of the screen, at the amplitude of the first signal peak. See [Figure 1-3](#).
 12. Press **Peak Search** to place the second marker on the highest signal with the new center frequency setting. See [Figure 1-3](#).
- The annotation in the upper right corner of the screen indicates the amplitude and frequency difference between the two markers.
13. To turn the markers off, press **Marker, Off**.

Figure 1-3 Frequency and Amplitude Difference Between Signals

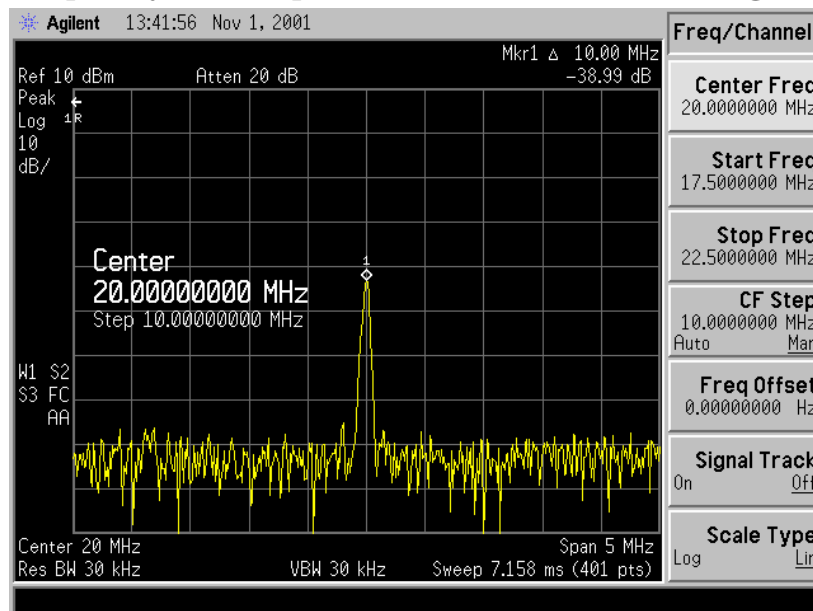

Resolving Signals of Equal Amplitude

Two equal-amplitude input signals that are close in frequency can appear as a single signal trace on the analyzer display. Responding to a single-frequency signal, a swept-tuned analyzer traces out the shape of the selected internal IF (intermediate frequency) filter. As you change the filter bandwidth, you change the width of the displayed response. If a wide filter is used and two equal-amplitude input signals are close enough in frequency, then the two signals will appear as one signal. If a narrow enough filter is used, the two input signals can be discriminated and will appear as separate peaks. Thus, signal resolution is determined by the IF filters inside the analyzer.

The bandwidth of the IF filter tells us how close together equal amplitude signals can be and still be distinguished from each other. The resolution bandwidth function selects an IF filter setting for a measurement. Typically, resolution bandwidth is defined as the 3 dB bandwidth of the filter. However, resolution bandwidth may also be defined as the 6 dB or impulse bandwidth of the filter.

Generally, to resolve two signals of equal amplitude, the resolution bandwidth must be less than or equal to the frequency separation of the two signals. If the bandwidth is equal to the separation and the video bandwidth is less than the resolution bandwidth, a dip of approximately 3 dB is seen between the peaks of the two equal signals, and it is clear that more than one signal is present. See [Figure 1-7](#).

In order to keep the analyzer measurement calibrated, sweep time is automatically set to a value that is inversely proportional to the square of the resolution bandwidth ($1/BW^2$ for resolution bandwidths ≥ 1 kHz). So, if the resolution bandwidth is reduced by a factor of 10, the sweep time is increased by a factor of 100 when sweep time and bandwidth settings are coupled. Sweep time is also a function of the type of detection selected (peak detection is faster than sample or average detection). For the shortest measurement times, use the widest resolution bandwidth that still permits discrimination of all desired signals. Sweeptime is also a function of which Detector is in use, Peak detector sweeps more quickly than Sample or Average detector. The analyzer allows you to select from 10 Hz (or 1 Hz with Option 1D5) to 3 MHz resolution bandwidths in a 1, 3, 10 sequence and select a 5 MHz resolution bandwidth. In addition you can select the three CISPR bandwidths (200 Hz, 9 kHz, and 120 kHz) for maximum measurement flexibility.

Resolving Signals Example:

Resolve two signals of equal amplitude with a frequency separation of 100 kHz.

1. Connect two sources to the analyzer input as shown in [Figure 1-4](#).

Figure 1-4 Setup for Obtaining Two Signals

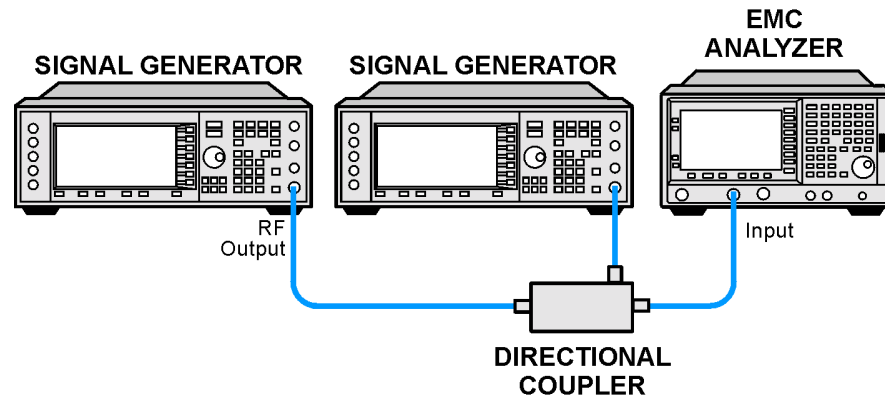

2. Set one source to 300 MHz. Set the frequency of the other source to 300.1 MHz. The amplitude of both signals should be approximately -20 dBm at the output of the bridge.
3. Set the analyzer as follows:
 - a. Press **Preset**, **Factory Preset** (if present).
 - b. Set the Y-Axis Units to dBm by pressing **AMPLITUDE**, **More**, **Y-Axis Units**, **dBm**.
 - c. Set the center frequency to 300 MHz by pressing **FREQUENCY**, **Center Freq**, **300**, **MHz**.
 - d. Set the span to 2 MHz by pressing **SPAN**, **Span**, **2**, **MHz**.
 - e. Set the resolution bandwidth to 300 kHz by pressing **BW/Avg**, **Res BW**, **300**, **kHz**.

A single signal peak is visible. See [Figure 1-5](#)

NOTE

If the signal peak is not present on the display, do the following:

1. Increase the span to 20 MHz by pressing **SPAN**, **Span**, **20**, **MHz**. The signal should be visible.
 2. Press **Peak Search**, **FREQUENCY**, **Signal Track** (On)
 3. Press **SPAN**, **2**, **MHz** to bring the signal to center screen.
 4. Press **FREQUENCY**, **Signal Track** (Off)
-

Figure 1-5 Unresolved Signals of Equal Amplitude

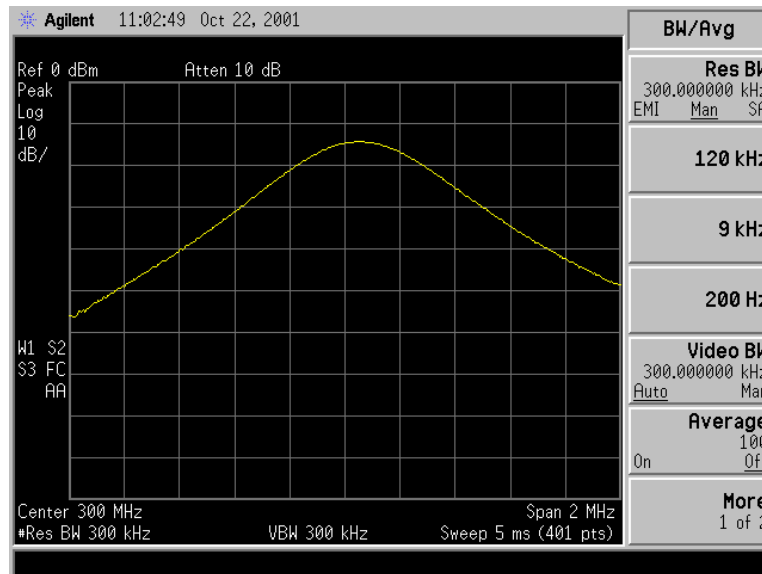

4. Since the resolution bandwidth must be less than or equal to the frequency separation of the two signals, a resolution bandwidth of 100 kHz must be used. Change the resolution bandwidth to 100 kHz by pressing **BW/Avg**, **Res BW**, 100, kHz. The peak of the signal has become flattened indicating that two signals may be present as shown in [Figure 1-6](#). Use the knob or step keys to further reduce the resolution bandwidth and better resolve the signals.

Figure 1-6 Resolving Signals of Equal Amplitude Before Reducing the Video Bandwidth

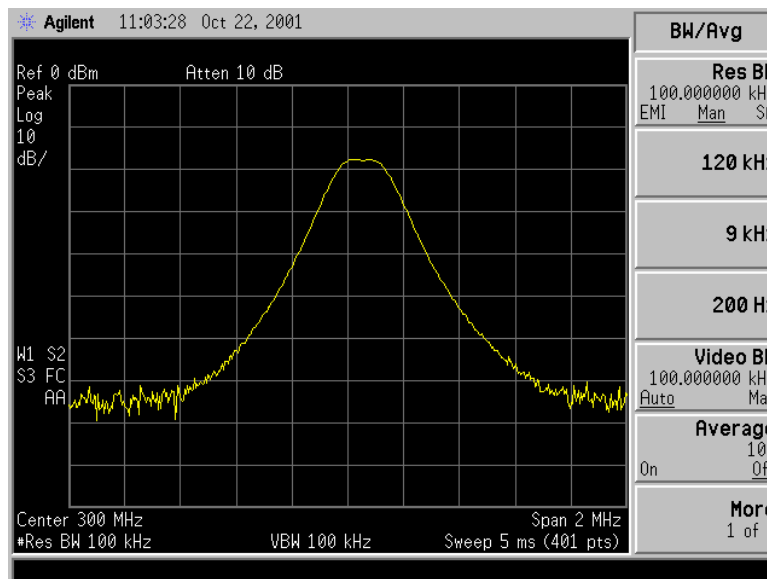

- Decrease the video bandwidth to 10 kHz, by pressing **Video BW**, **10, kHz**. Two signals are now visible as shown in **Figure 1-7**. Use the front-panel knob or step keys to further reduce the resolution bandwidth and better resolve the signals.

Figure 1-7 Resolving Signals of Equal Amplitude After Reducing the Video Bandwidth

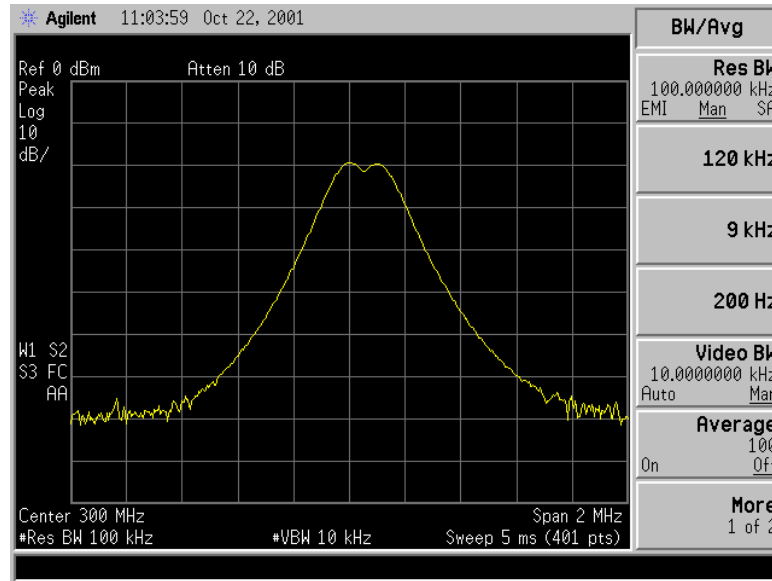

As the resolution bandwidth is decreased, resolution of the individual signals is improved and the sweep time is increased. For fastest measurement times, use the widest possible resolution bandwidth. Under factory preset conditions, the resolution bandwidth is “coupled” (or linked) to the center frequency.

Since the resolution bandwidth has been changed from the coupled value, a # mark appears next to Res BW in the lower-left corner of the screen, indicating that the resolution bandwidth is uncoupled. (For more information on coupling, refer to the Auto Couple key description in the Agilent Technologies EMC Analyzers User’s Guide.)

NOTE To resolve two signals of equal amplitude with a frequency separation of 200 kHz, the resolution bandwidth must be less than the signal separation, and resolution of 100 kHz must be used. The next larger filter, 300 kHz, would exceed the 200 kHz separation and would not resolve the signals.

Resolving Small Signals Hidden by Large Signals

When dealing with the resolution of signals that are close together and not equal in amplitude, you must consider the shape of the IF filter of the analyzer, as well as its 3 dB bandwidth. (See “[Resolving Signals of Equal Amplitude](#)” on page 14 for more information.) The shape of a filter is defined by the selectivity, which is the ratio of the 60 dB bandwidth to the 3 dB bandwidth. (Generally, the IF filters in this analyzer have shape factors of 15:1 or less for resolution bandwidths ≥ 1 kHz and 5:1 or less for resolution bandwidths ≤ 300 Hz). If a small signal is too close to a larger signal, the smaller signal can be hidden by the skirt of the larger signal. To view the smaller signal, you must select a resolution bandwidth such that the separation between the two signals (a) is greater than half the filter width of the larger signal (k) measured at the amplitude level of the smaller signal. See [Figure 1-8](#).

Figure 1-8

Resolution Bandwidth Requirements for Resolving Small Signals

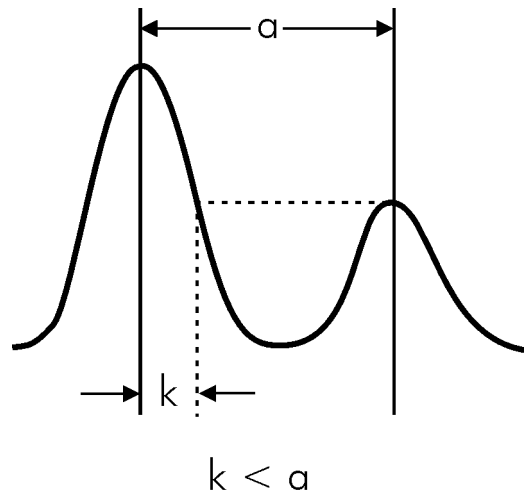

bb91a

Resolving Signals Example:

Resolve two input signals with a frequency separation of 155 kHz and an amplitude separation of 60 dB.

1. Connect two sources to the analyzer input as shown in [Figure 1-9](#).

Figure 1-9 Setup for Obtaining Two Signals

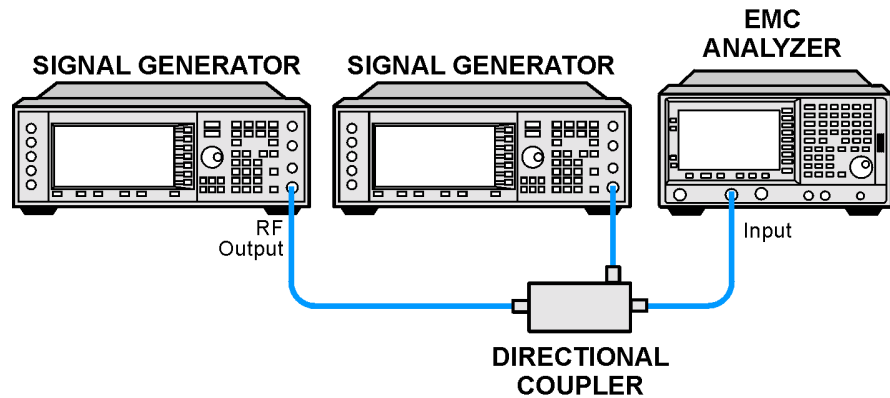

2. Set one source to 300 MHz at -10 dBm.
3. Set the second source to 300.155 MHz, so that the signal is 155 kHz higher than the first signal. Set the amplitude of the signal to -70 dBm (60 dB below the first signal).
4. Set the analyzer as follows:
 - a. Press **Preset**, **Factory Preset** (if present).
 - b. Set the Y-Axis Units to dBm by pressing **AMPLITUDE**, **More**, **Y-Axis Units**, **dBm**.
 - c. Set the center frequency to 300 MHz by pressing **FREQUENCY**, **Center Freq**, **300**, **MHz**.
 - d. Set the span to 2 MHz by pressing **SPAN**, **Span**, **2**, **MHz**.

NOTE

If the signal peak is not present on the display, do the following:

1. Increase the span to 20 MHz by pressing **SPAN**, **Span**, **20**, **MHz**. The signal should now be visible.
 2. Press **Peak Search**, **FREQUENCY**, **Signal Track** (On)
 3. Press **SPAN**, **2**, **MHz** to bring the signal to center screen.
 4. Press **FREQUENCY**, **Signal Track** (Off)
-
- e. Set the resolution bandwidth to spectrum analyzer coupling by pressing **BW/Avg**, **Resolution BW** (SA).

5. Set the 300 MHz signal to the reference level by pressing **Mkr** → and then **Mkr** → **Ref Lvl**.

If a 10 kHz filter with a typical shape factor of 15:1 is used, the filter will have a bandwidth of 150 kHz at the 60 dB point. The half-bandwidth (75 kHz) is narrower than the frequency separation, so the input signals will be resolved. See [Figure 1-10](#).

Figure 1-10 Signal Resolution with a 10 kHz Resolution Bandwidth

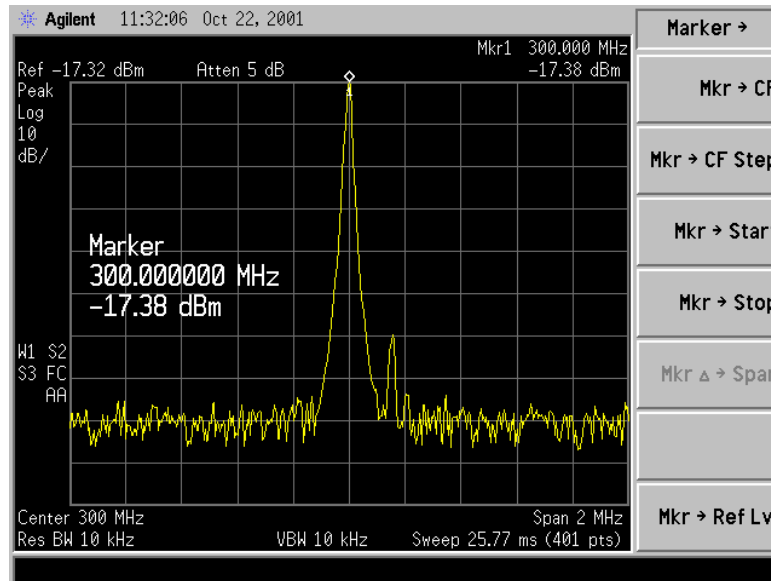

6. Place a marker on the smaller signal by pressing **Marker**, **Delta**, **Peak Search**, **Next Pk Right**. Refer to [Figure 1-11](#).

Figure 1-11 Signal Resolution with a 10 kHz Resolution Bandwidth

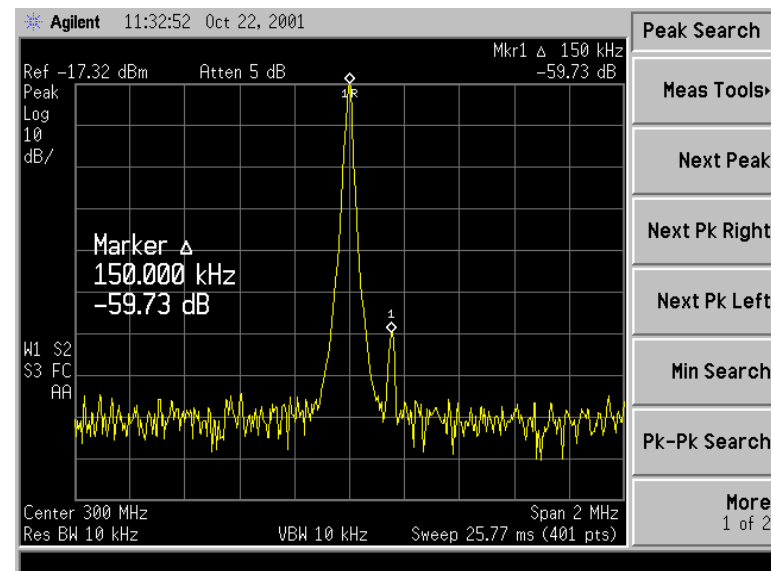

- Set the resolution bandwidth to 30 kHz by pressing **BW/Avg**, **Res BW**, **30**, **kHz**.

When a 30 kHz filter is used, the 60 dB bandwidth could be as wide as 450 kHz. Since the half-bandwidth (225 kHz) is wider than the frequency separation, the signals most likely will not be resolved. See [Figure 1-12](#). (In this example, we used the 60 dB bandwidth value. To determine resolution capability for intermediate values of amplitude level differences, assume the filter skirts between the 3 dB and 60 dB points are approximately straight.)

Figure 1-12 Signal Resolution with a 30 kHz Resolution Bandwidth

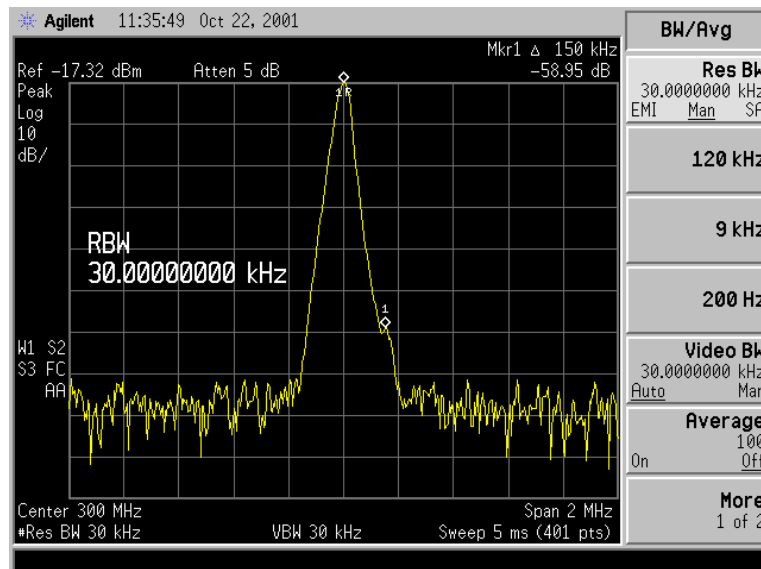

Making Better Frequency Measurements

A built-in frequency counter increases the resolution and accuracy of the frequency readout. When using this function, if the ratio of the resolution bandwidth to the span is too small (less than 0.002), the Marker Count: Widen Res BW message appears on the display. It indicates that the resolution bandwidth is too narrow.

Better Frequency Measurement Example:

Increase the resolution and accuracy of the frequency readout on the signal of interest.

1. Perform a factory preset by pressing **Preset**, **Factory Preset** (if present).
2. Turn on the internal 50 MHz amplitude reference signal of the analyzer as follows:
 - For the E7401A, use the internal 50 MHz amplitude reference signal of the analyzer as the signal being measured. Press **Input/Output**, **Amptd Ref (On)**.
 - For all other models connect a cable between the front-panel AMPTD REF OUT to the analyzer INPUT, then press **Input/Output**, **Amptd Ref Out (On)**.
3. Set the center frequency to 50 MHz by pressing **FREQUENCY**, **Center Freq**, **50**, **MHz**.
4. Set the span to 80 MHz by pressing **SPAN**, **Span**, **80**, **MHz**.
5. Set the Y-Axis Units to dBm by pressing **AMPLITUDE**, **More**, **Y-Axis Units**, **dBm**.
6. Set the resolution bandwidth to spectrum analyzer coupling pressing **BW/Avg**, **Resolution BW (SA)**.
7. Press **Freq Count**. (Note that **Marker Count** has **On** underlined turning the frequency counter on.) The frequency and amplitude of the marker and the word **Marker** will appear in the active function area (this is not the counted result). The counted result appears in the upper-right corner of the display.
8. Move the marker, with the front-panel knob, half-way down the skirt of the signal response. Notice that the readout in the active frequency function changes while the counted frequency result (upper-right corner of display) does not. See [Figure 1-13](#). To get an accurate count, you do not need to place the marker at the exact peak of the signal response.

NOTE Marker count properly functions only on CW signals or discrete spectral components. The marker must be >26 dB above the noise.

9. Increase the counter resolution by pressing **Resolution** and then entering the desired resolution using the step keys or the numbers keypad. For example, press 10, Hz. The marker counter readout is in the upper-right corner of the screen. The resolution can be set from 1 Hz to 100 kHz.
10. The marker counter remains on until turned off. Turn off the marker counter by pressing **Freq Count**, then **Marker Count (Off)**. **Marker, Off** also turns the marker counter off.

Figure 1-13 Using Marker Counter

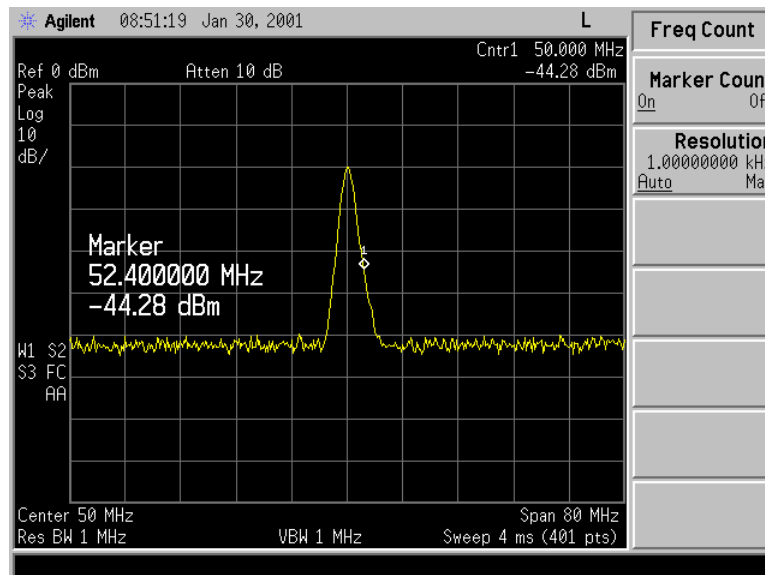

Decreasing the Frequency Span Around the Signal

Using the analyzer signal track function, you can quickly decrease the span while keeping the signal at center frequency. This is a fast way to take a closer look at the area around the signal to identify signals that would otherwise not be resolved.

Decreasing the Frequency Span Example:

Examine a signal in a 200 kHz span.

1. Perform a factory preset by pressing **Preset, Factory Preset** (if present).
2. Turn on the internal 50 MHz amplitude reference signal of the analyzer as follows:
 - For the E7401A, use the internal 50 MHz amplitude reference signal of the analyzer as the signal being measured. Press **Input/Output, Amptd Ref (On)**.
 - For all other models connect a cable between the front-panel AMPTD REF OUT to the analyzer INPUT, then press **Input/Output, Amptd Ref Out (On)**.
3. Set the start frequency to 20 MHz by pressing **FREQUENCY, Start Freq, 20, MHz**.
4. Set the stop frequency to 1 GHz by pressing **FREQUENCY, Stop Freq, 1, GHz**.
5. Set the Y-Axis Units to dBm by pressing **AMPLITUDE, More, Y-Axis Units, dBm**.
6. Set the resolution bandwidth to spectrum analyzer coupling pressing **BW/Avg, Resolution BW (SA)**.
7. Press **Peak Search** to place a marker at the peak. See [Figure 1-14](#).

Figure 1-14 Detected Signal

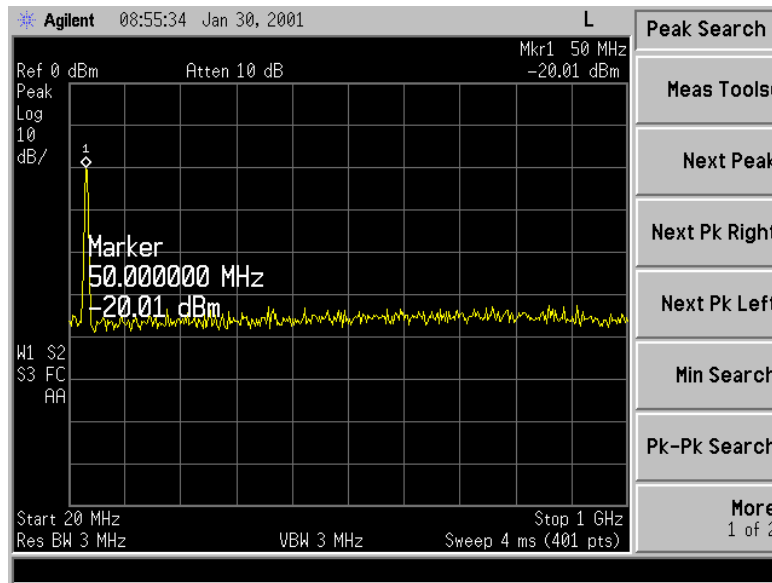

- Turn on the frequency tracking function by press **FREQUENCY** and **Signal Track** and the signal will move to the center of the screen, if it is not already positioned there. See figure [Figure 1-15](#). (Note that the marker must be on the signal before turning signal track on.)

Because the signal track function automatically maintains the signal at the center of the screen, you can reduce the span quickly for a closer look. If the signal drifts off of the screen as you decrease the span, use a wider frequency span. (You can also use **Span Zoom**, in the **SPAN** menu, as a quick way to perform the **Peak Search**, **FREQUENCY**, **Signal Track**, **SPAN** key sequence.)

Figure 1-15 Signal with Signal Tracking On

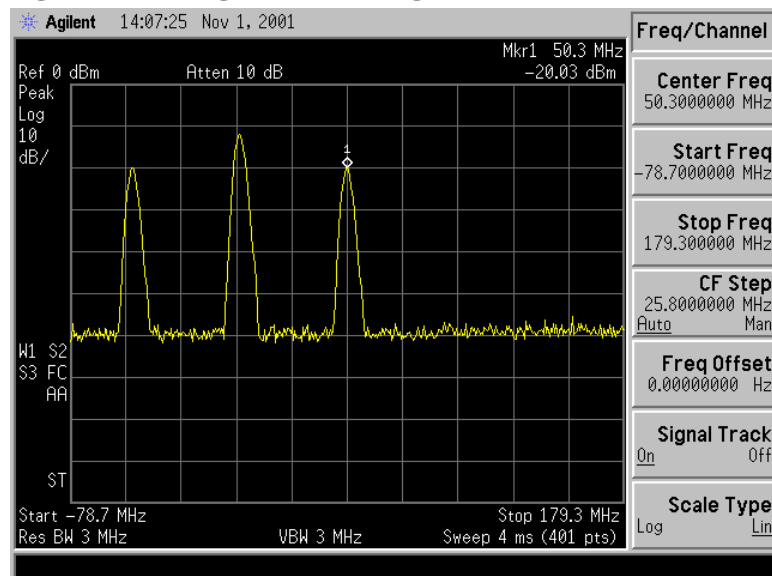

- Reduce span and resolution bandwidth to zoom in on the marked signal by pressing **SPAN**, **Span**, **200**, **kHz**.

If the span change is large enough, span will decrease in steps as automatic zoom is completed. See [Figure 1-16](#). You can also use the front-panel knob or step keys to decrease the span and resolution bandwidth values.

- Press **FREQUENCY**, **Signal Track** (so that **Off** is underlined) to turn off the signal track function.

Figure 1-16 After Zooming In on the Signal

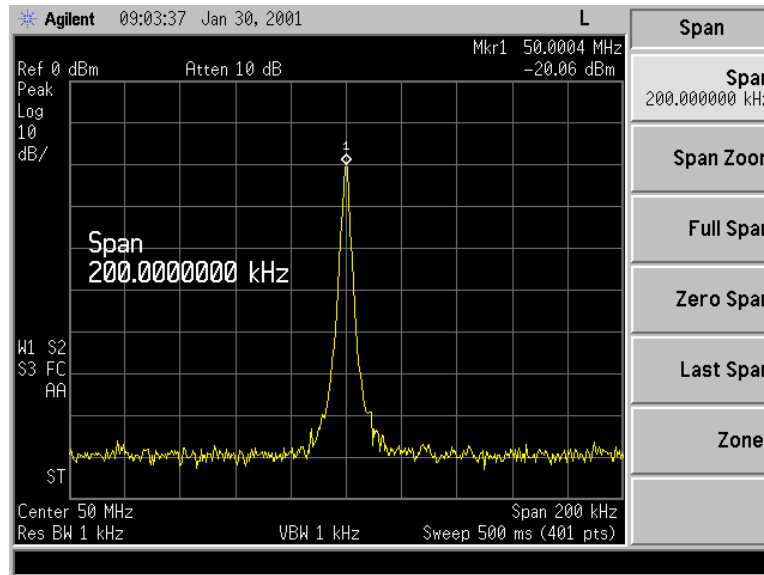

Tracking Drifting Signals

The signal track function is useful for tracking drifting signals that drift relatively slowly. To place a marker on the signal you wish to track, use **Peak Search**. Pressing **FREQUENCY, Signal Track (On)** will bring that signal to the center frequency of the graticule and adjust the center frequency every sweep to bring the selected signal back to the center. A quick way to perform the **Peak Search, FREQUENCY, Signal Track, SPAN** key sequence is to use the **Span Zoom** key in the **SPAN** menu.

Note that the primary function of the signal track function is to track unstable signals, not to track a signal as the center frequency of the analyzer is changed. If you choose to use the signal track function when changing center frequency, check to ensure that the signal found by the tracking function is the correct signal.

Tracking Signal Drift Example 1:

Use the signal track function to keep a drifting signal at the center of the display and monitor its change.

This example requires a signal generator. The frequency of the signal generator will be changed while you view the signal on the display of the analyzer.

1. Connect a signal generator to the analyzer input.
2. Set the signal generator frequency to 300 MHz with an amplitude of -20 dBm.
3. Set the analyzer as follows:
 - a. Press **Preset, Factory Preset** (if present).
 - b. Set the Y-Axis Units to dBm by pressing **AMPLITUDE, More, Y-Axis Units, dBm**.
 - c. Set the resolution bandwidth to the spectrum analyzer coupling by pressing **BW/Avg, Resolution BW (SA)**. See [Figure 1-17](#).
 - d. Set the center frequency to 300 MHz by pressing **FREQUENCY, Center Freq, 300, MHz**.

Figure 1-17 Signal With Default Span

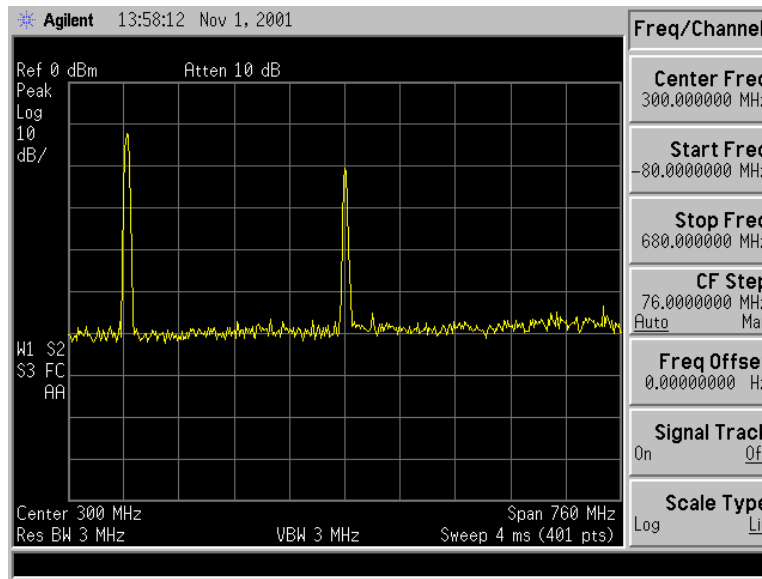

4. Press **Peak Search**.
5. Set the span to 10 MHz by pressing **SPAN, Span, 10, MHz**. See [Figure 1-18](#).

Figure 1-18 Signal With 10 MHz Span

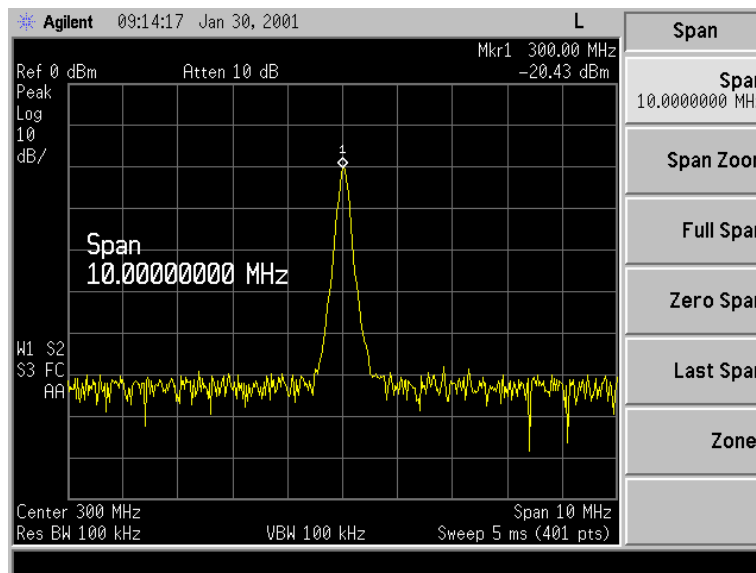

6. Press **SPAN, Span Zoom, 500, kHz**.

Notice that the signal has been held in the center of the display. See [Figure 1-19](#).

Figure 1-19 Signal With 500 kHz Span

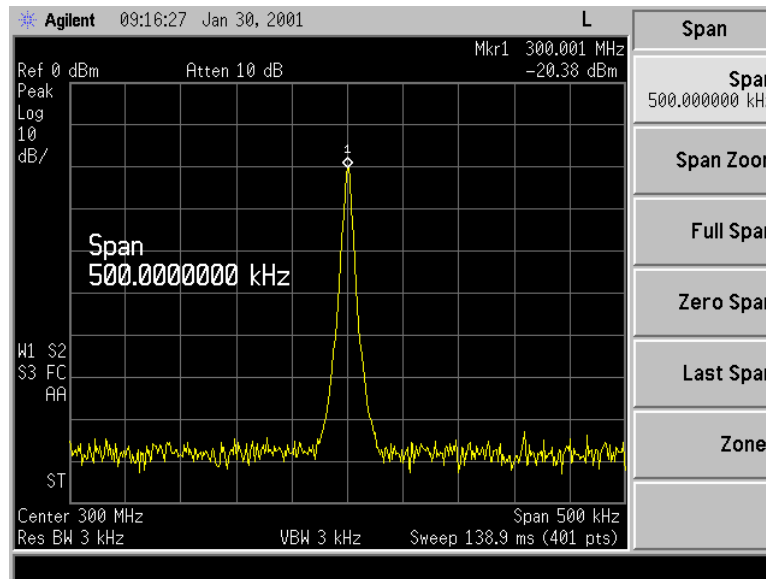

7. Tune the frequency of the signal generator in 10 kHz increments. Notice that the center frequency of the analyzer also changes in 10 kHz increments, centering the signal with each increment. See Figure 1-20. Note that the center frequency has changed.

Figure 1-20 Using Span Zoom to Track a Drifting Signal

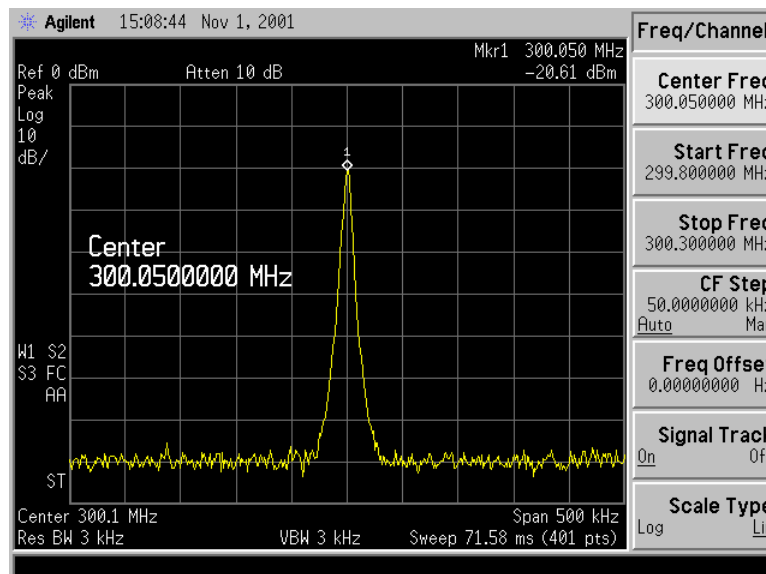

8. The signal frequency drift can be read from the screen if both the signal track and marker delta functions are active. Set the analyzer and signal generator as follows:
 - a. Press **Marker, Delta**.
 - b. Tune the frequency of the signal generator. The marker readout indicates the change in frequency and amplitude as the signal drifts. See [Figure 1-21](#).

Figure 1-21 Using Signal Tracking to Track a Drifting Signal

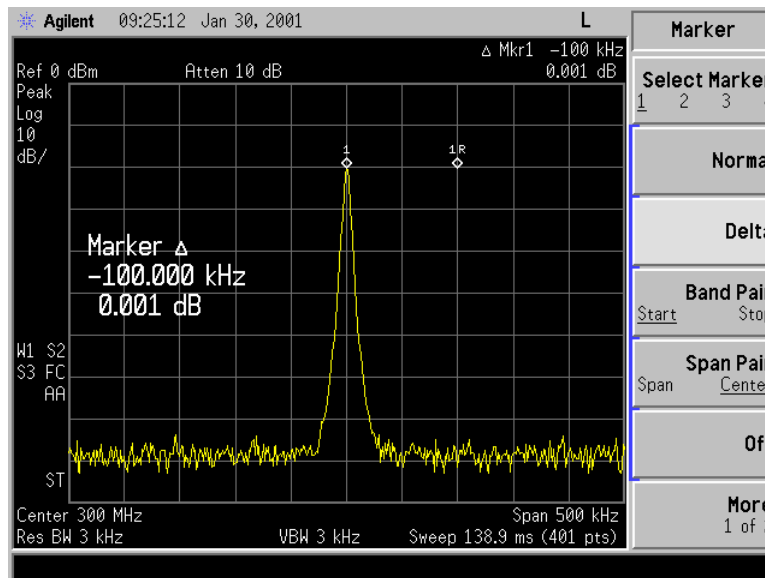

Tracking Signal Drift Example 2:

The analyzer can measure the short- and long-term stability of a source. The maximum amplitude level and the frequency drift of an input signal trace can be displayed and held by using the maximum-hold function. You can also use the maximum hold function if you want to determine how much of the frequency spectrum a signal occupies.

1. Connect a signal generator to the analyzer input.
2. Set the signal generator frequency to 300 MHz with an amplitude of -20 dBm.
3. Set the analyzer as follows:
 - a. Press **Preset, Factory Preset** (if present).
 - b. Set the Y-Axis Units to dBm by pressing **AMPLITUDE, More, Y-Axis Units, dBm**.
 - c. Set the resolution bandwidth to spectrum analyzer coupling by pressing **BW/Avg, Resolution BW (SA)**.

- d. Set the center frequency to 300 MHz by pressing **FREQUENCY**, **Center Freq**, **300**, **MHz**. See [Figure 1-22](#).

Figure 1-22 Signal With Default Span

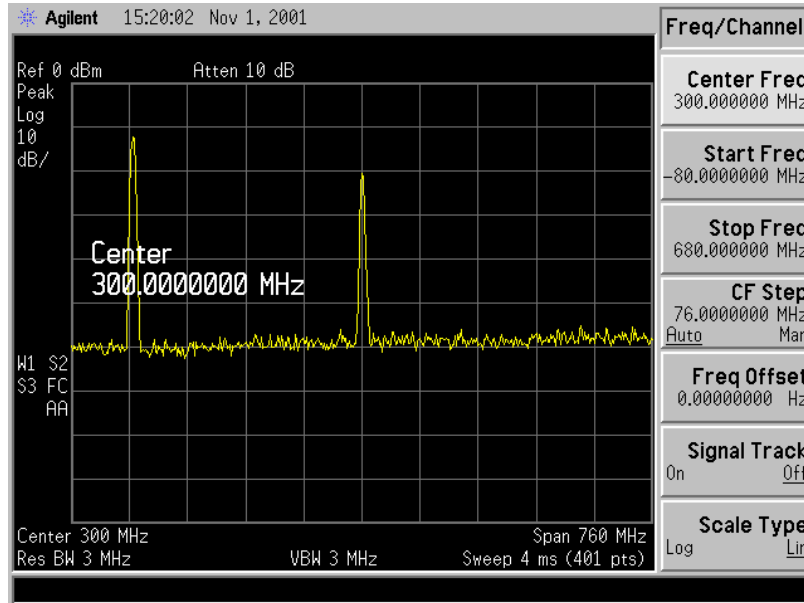

4. Press **Peak Search**.
5. Set the span to 10 MHz by pressing **SPAN**, **Span**, **10**, **MHz**. See [Figure 1-23](#).

Figure 1-23 Signal With 10 MHz Span

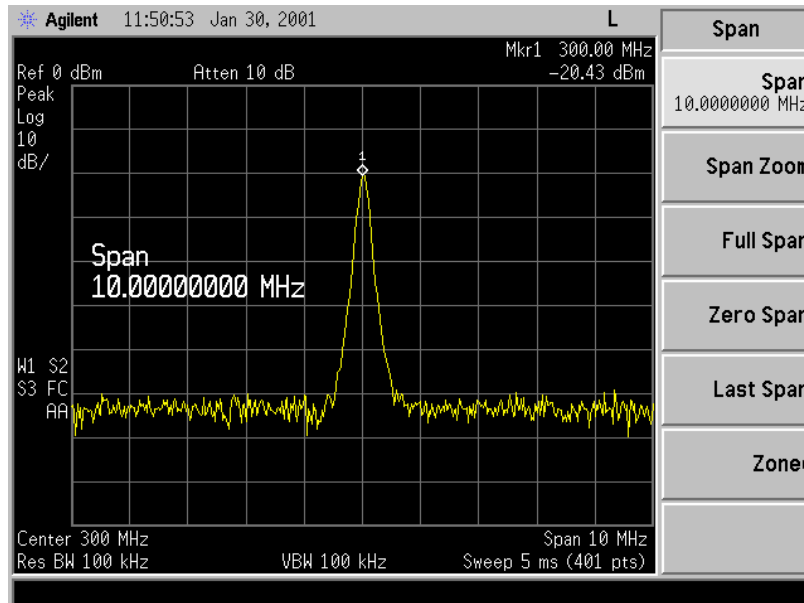

6. Press **SPAN**, **Span Zoom**, **500, kHz**.

Notice that the signal has been held in the center of the display. See [Figure 1-24](#).

Figure 1-24 Signal With 500 KHz Span

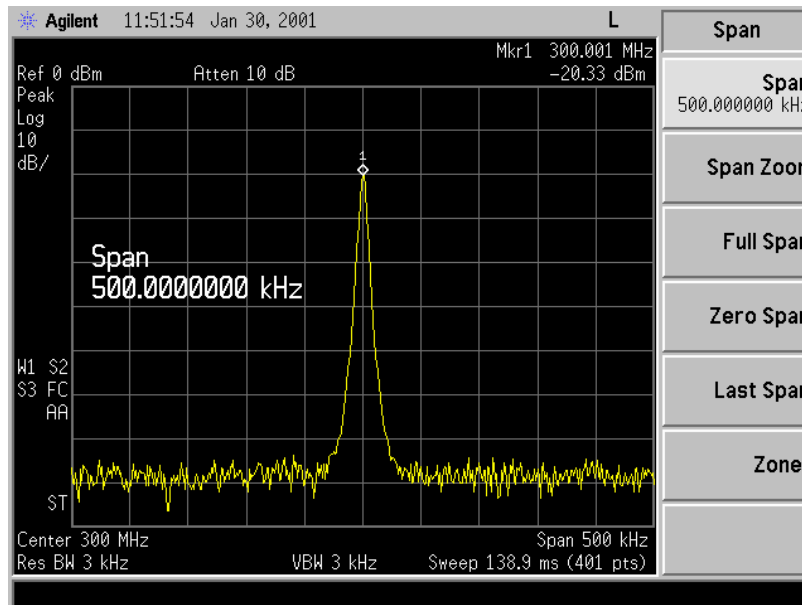

7. Turn off the signal track function by pressing **FREQUENCY**, **Signal Track (Off)**.
8. To measure the excursion of the signal, press **Trace/View**, **Max Hold**. As the signal varies, maximum hold maintains the maximum responses of the input signal.

Annotation on the left side of the screen indicates the trace mode. For example, M1 S2 S3 indicates trace 1 is in maximum-hold mode, trace 2 and trace 3 are in store-blank mode.
9. Press **Trace/View**, **Trace**, to select trace 2. (Trace 2 is selected when 2 is underlined.)
10. Press **Clear Write** to place trace 2 in clear-write mode, which displays the current measurement results as it sweeps. Trace 1 remains in maximum hold mode, showing the frequency shift of the signal.
11. Slowly change the frequency of the signal generator ± 50 kHz in 1 kHz increments. Your analyzer display should look similar to [Figure 1-25](#).

Figure 1-25 Viewing a Drifting Signal With Max Hold and Clear Write

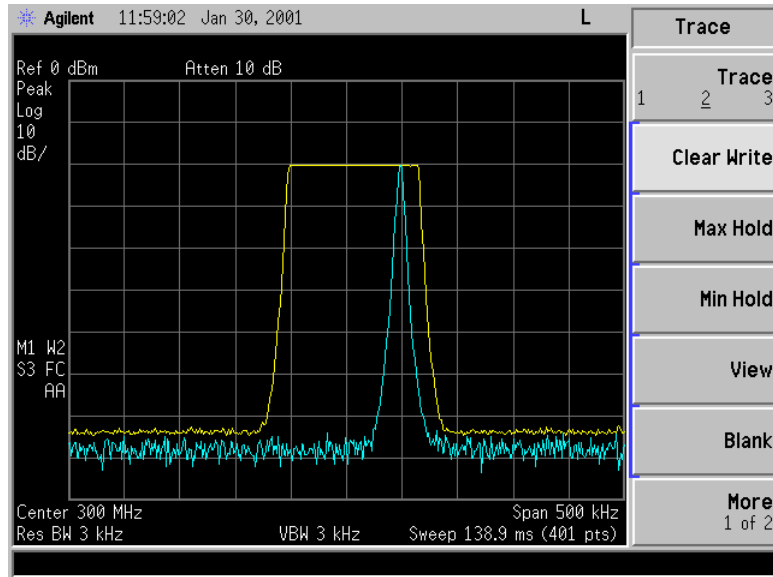

Measuring Low Level Signals

The ability of the analyzer to measure low level signals is limited by the noise generated inside the analyzer. A signal may be masked by the noise floor so that it is not visible. This sensitivity to low level signals is affected by the measurement setup.

The analyzer input attenuator and bandwidth settings affect the sensitivity by changing the signal-to-noise ratio. The attenuator affects the level of a signal passing through the instrument, whereas the bandwidth affects the level of internal noise without affecting the signal. In the first two examples in this section, the attenuator and bandwidth settings are adjusted to view low level signals.

If, after adjusting the attenuation and resolution bandwidth, a signal is still near the noise, visibility can be improved by using the video bandwidth and video averaging functions, as demonstrated in the third and fourth examples.

Measuring Low Level Signals Example 1:

If a signal is very close to the noise floor, reducing input attenuation brings the signal out of the noise. Reducing the attenuation to 0 dB maximizes signal power in the analyzer.

CAUTION

The total power of all input signals at the analyzer input must not exceed the maximum power level for the analyzer.

1. Connect a signal generator to the analyzer input.
2. Set the signal generator frequency to 300 MHz with an amplitude of -80 dBm.
3. On the analyze, perform a factory preset by pressing **Preset, Factory Preset** (if present).
4. Set the center frequency of the analyzer to 300 MHz by pressing **FREQUENCY, Center Freq, 300, MHz**.
5. Set the span to 5 MHz by pressing **SPAN, Span, 5, MHz**.
6. Set the resolution bandwidth to spectrum analyzer coupling by pressing **BW/Avg, Res BW (SA)**.
7. Set the Y-Axis Units to dBm by pressing **AMPLITUDE, More, Y-Axis Units, dBm**.
8. Set the reference level to -40 dBm by pressing **AMPLITUDE, Ref Level, -40, dBm**.
9. Place the signal at center frequency by pressing **Peak Search, Marker→, Mkr→CF**.

- Reduce the span to 1 MHz. Press **SPAN**, **Span**, and then use the step-down key (\downarrow) until the span is set to 1 MHz. See [Figure 1-26](#).

Figure 1-26 Low-Level Signal

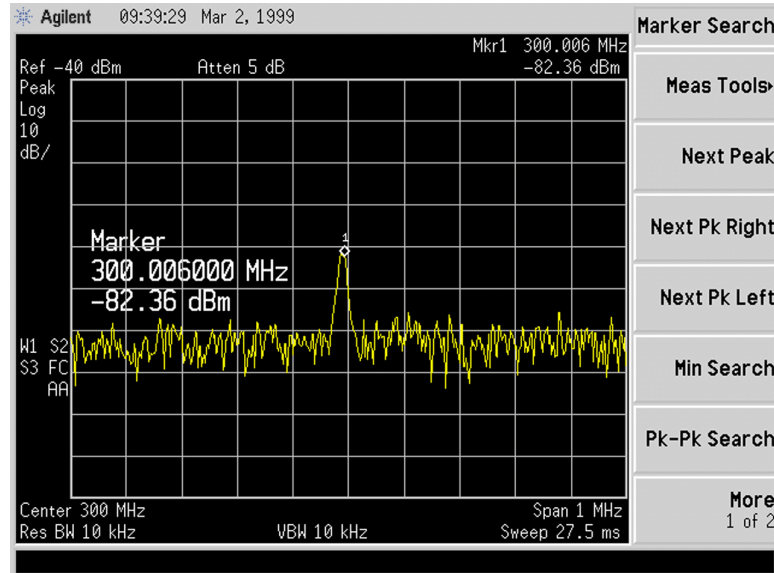

- Press **AMPLITUDE**, **Attenuation**. Press the step-up key (\uparrow) to select 20 dB attenuation. Increasing the attenuation moves the noise floor closer to the signal.

A # mark appears next to the **Atten** annotation at the top of the display, indicating the attenuation is no longer coupled to other analyzer settings.

Figure 1-27 Using 20 dB Attenuation

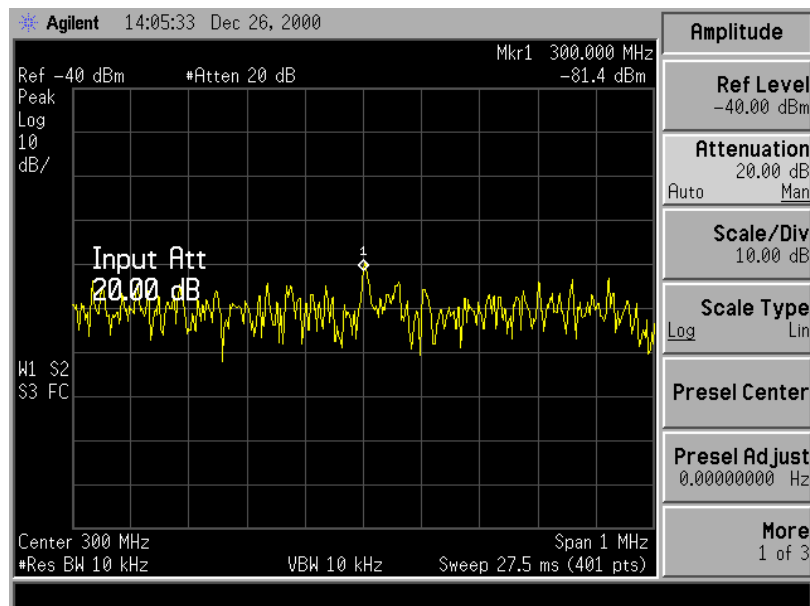

- To see the signal more clearly, enter 0 dB. Zero decibels of attenuation makes the signal more visible. See [Figure 1-28](#).

Figure 1-28 Using 0 dB Attenuation

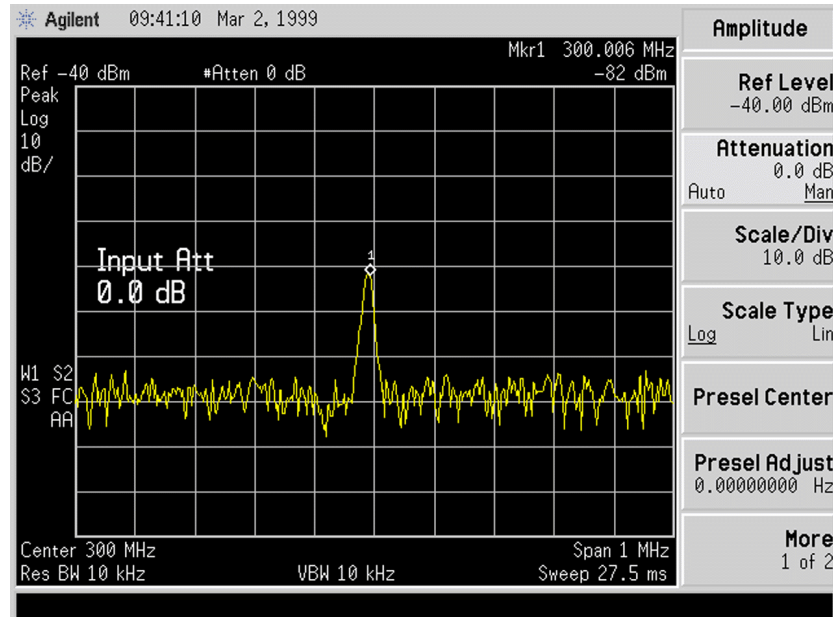

CAUTION

Before connecting other signals to the analyzer input, increase the RF attenuation to protect the analyzer input: press **Attenuation** so that **Auto** is underlined or press **Auto Couple**.

Measuring Low Level Signals Example 2:

The resolution bandwidth can be decreased to view low level signals.

- Connect a signal generator to the analyzer input.
- Set the signal generator frequency to 300 MHz with an amplitude of -80 dBm.
- On the analyzer, perform a factory preset by pressing **Preset**, **Factory Preset** (if present).
- Set the center frequency of the analyzer to 300 MHz by pressing **FREQUENCY**, **Center Freq**, **300**, **MHz**.
- Set the span to 5 MHz by pressing **SPAN**, **Span**, **5**, **MHz**.
- Set the resolution bandwidth to spectrum analyzer coupling by pressing **BW/Avg**, **Res BW** (SA).
- Set the Y-Axis Units to dBm by pressing **AMPLITUDE**, **More**, **Y-Axis Units**, **dBm**.
- Set the reference level to -40 dBm by pressing **AMPLITUDE**, **Ref Level**, **-40**, **dBm**.

9. Place the signal at center frequency by pressing **Peak Search**, **Marker**→, **Mkr**→**CF**.
10. Press **BW/Avg**, **Res BW**, and then ↓. The low level signal appears more clearly because the noise level is reduced. As shown in [Figure 1-29](#).

A # mark appears next to the **Res BW** annotation at the lower left corner of the screen, indicating that the resolution bandwidth is uncoupled. As the resolution bandwidth is reduced, the sweep time is increased to maintain calibrated data.

Figure 1-29 Decreasing Resolution Bandwidth

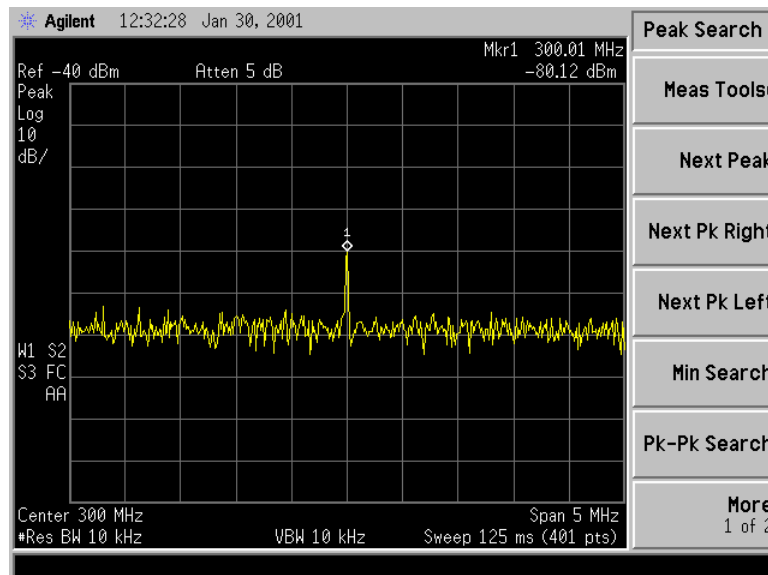

Measuring Low Level Signals Example 3:

Narrowing the video filter can be useful for noise measurements and observation of low level signals close to the noise floor. The video filter is a post-detection low-pass filter that smooths the displayed trace. When signal responses near the noise level of the analyzer are visually masked by the noise, the video filter can be narrowed to smooth this noise and improve the visibility of the signal. (Reducing video bandwidths requires slower sweep times to keep the analyzer calibrated.)

Using the video bandwidth function, measure the amplitude of a low level signal.

1. Connect a signal generator to the analyzer input.
2. Set the signal generator frequency to 300 MHz with an amplitude of -80 dBm.

3. On the analyzer, perform a factory preset by pressing **Preset, Factory Preset** (if present).
4. Set the center frequency of the analyzer to 300 MHz by pressing **FREQUENCY, Center Freq, 300, MHz**.
5. Set the span to 5 MHz by pressing **SPAN, Span, 5, MHz**.
6. Set the resolution bandwidth to spectrum analyzer coupling by pressing **BW/Avg, Res BW (SA)**.
7. Set the Y-Axis Units to dBm by pressing **AMPLITUDE, More, Y-Axis Units, dBm**.
8. Set the reference level to -40 dBm by pressing **AMPLITUDE, Ref Level, -40, dBm**.
9. Place the signal at center frequency by pressing **Peak Search, Marker→, Mkr→CF**. See [Figure 1-30](#).

Figure 1-30 30 kHz Video Bandwidth

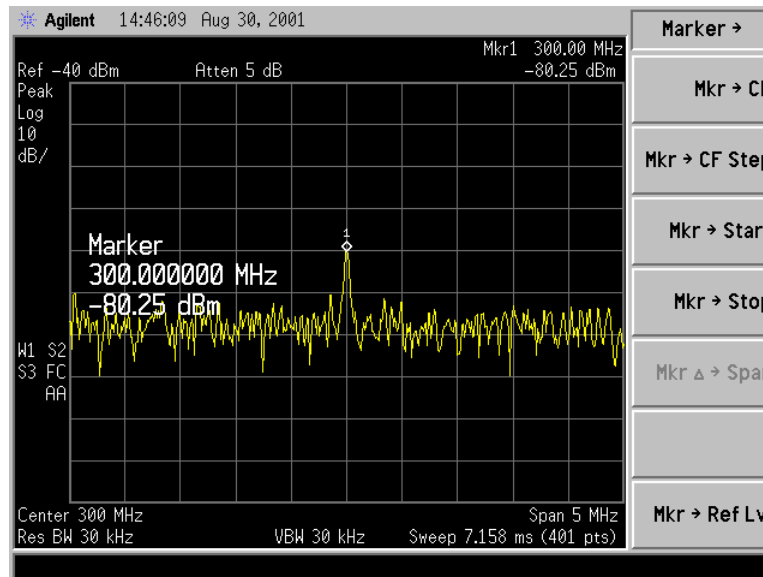

10. Narrow the video bandwidth by pressing **BW/Avg, Video BW**, and the step-down key (\downarrow). This clarifies the signal by smoothing the noise, which allows better measurement of the signal amplitude.

A # mark appears next to the VBW annotation at the bottom of the screen, indicating that the video bandwidth is not coupled to the resolution bandwidth. See [Figure 1-31](#). As the video bandwidth is reduced, the sweep time is increased to maintain calibrated data.

Instrument preset conditions couple the video bandwidth to the resolution bandwidth. If the bandwidths are uncoupled when video bandwidth is the active function, pressing **Video BW** (so that Auto is underlined) recouples the bandwidths.

NOTE The video bandwidth must be set wider than the resolution bandwidth when measuring impulse noise levels.

Figure 1-31 Decreasing Video Bandwidth

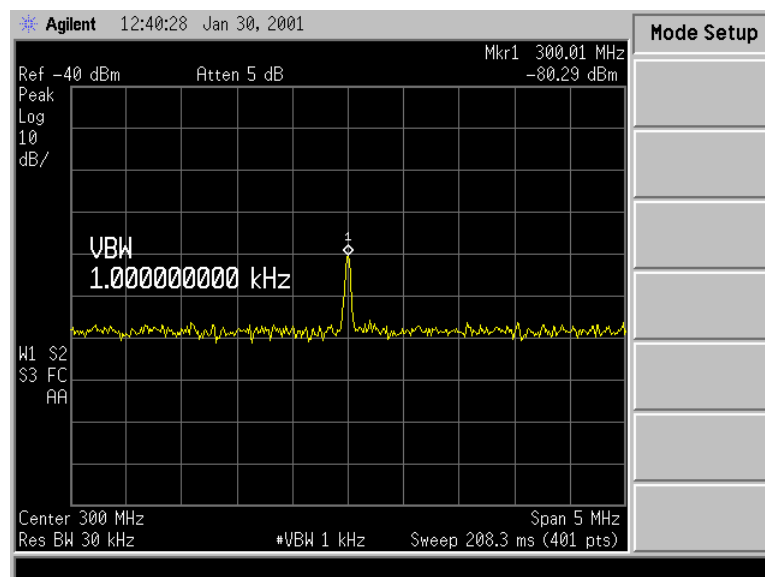

Measuring Low Level Signals Example 4:

If a signal level is very close to the noise floor, video averaging is another way to make the signal more visible.

NOTE The time required to construct a full trace that is averaged to the desired degree is approximately the same when using either the video bandwidth or the video averaging technique. The video bandwidth technique completes the averaging as a slow sweep is taken, whereas the video averaging technique takes many sweeps to complete the average. Characteristics of the signal being measured, such as drift and duty cycle, determine which technique is appropriate.

Video averaging is a digital process in which each trace point is averaged with the previous trace-point average. Selecting **Average Type, Video Avg** and **Average (On)** changes the detection mode from peak to sample. The result is a sudden drop in the displayed noise level. The sample mode displays the instantaneous value of the signal at the end of the time or frequency interval represented by each display point, rather than the value of the peak during the interval. Sample mode is not used to measure signal amplitudes accurately because it may not find the true peak of the signal.

Video averaging clarifies low-level signals in wide bandwidths by averaging the signal and the noise. As the analyzer takes sweeps, you can watch video averaging smooth the trace.

1. Connect a signal generator to the analyzer input.
2. Set the signal generator frequency to 300 MHz with an amplitude of -80 dBm.
3. On the analyzer, perform a factory preset by pressing **Preset**, **Factory Preset** (if present).
4. Set the center frequency of the analyzer to 300 MHz by pressing **FREQUENCY**, **Center Freq**, **300**, **MHz**.
5. Set the span to 5 MHz by pressing **SPAN**, **Span**, **5**, **MHz**.
6. Set the resolution bandwidth to spectrum analyzer coupling by pressing **BW/Avg**, **Res BW** (SA).
7. Set the Y-Axis Units to dBm by pressing **AMPLITUDE**, **More**, **Y-Axis Units**, **dBm**.
8. Set the reference level to -40 dBm by pressing **AMPLITUDE**, **Ref Level**, **-40** , **dBm**.
9. Place the signal at center frequency by pressing **Peak Search**, **Marker**→, **Mkr**→**CF**. See [Figure 1-32](#).

Figure 1-32 Without Video Averaging

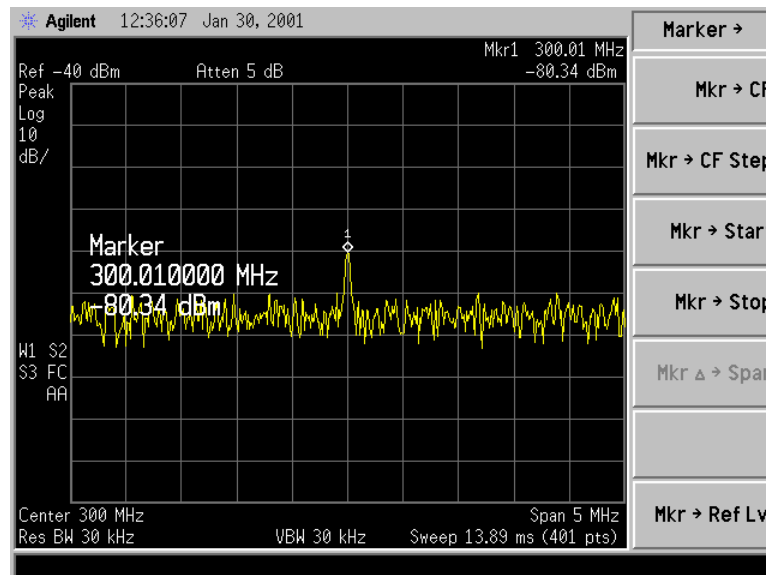

10. Pressing **BW/Avg**, **Average Type**, (**Video Avg**), **Average (On)**, initiates the video averaging routine. As the averaging routine smooths the trace, low level signals become more visible. **Average 100** appears in the active function block. The number represents the number of samples (or sweeps) taken to complete the averaging routine. Once the set number of sweeps has been completed, the analyzer continues to provide a running average based on this set number.

- To set the number of samples, use the numeric keypad. For example, press **Average (On)**, **25**, **Enter**. As shown in [Figure 1-33](#).

During averaging, the current sample number appears at the left side of the graticule. The number of samples equals the number of sweeps in the averaging routine. Changes in active function settings, such as the center frequency or reference level, will restart the sampling. The sampling will also restart if video averaging is turned off and then on again. To see the sample number increment, turn video averaging off and then on again by pressing **Average (Off)**, **Average (On)**.

Figure 1-33 Using the Video Averaging Function

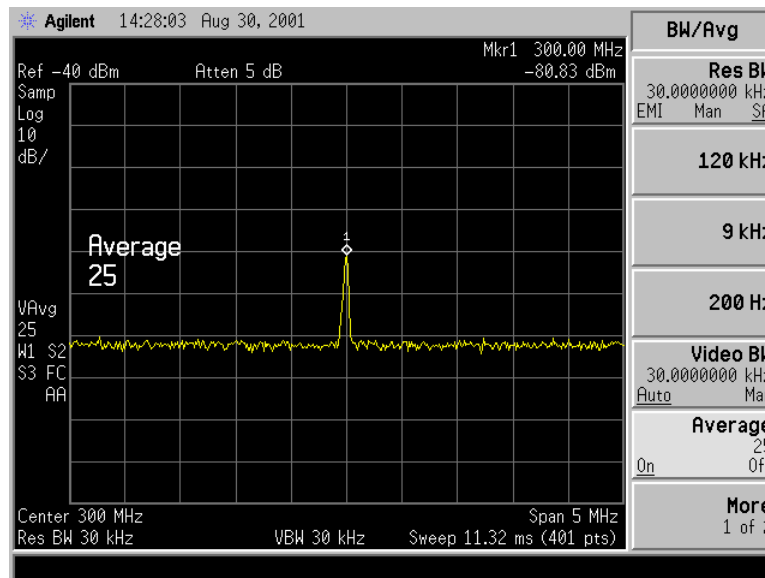

Identifying Distortion Products

Distortion from the Analyzer

High level input signals may cause analyzer distortion products that could mask the real distortion measured on the input signal. Using trace 2 and the RF attenuator, you can determine which signals, if any, are internally generated distortion products.

Identifying Analyzer Generated Distortion Example:

Using a signal from a signal generator, determine whether the harmonic distortion products are generated by the analyzer.

1. Connect a signal generator to the analyzer INPUT.
2. Set the signal generator frequency to 200 MHz and the amplitude to 0 dBm.
3. On the analyzer, perform a factory preset by pressing **Preset**, **Factory Preset** (if present).
4. Set the Y-Axis Units to dBm by pressing **AMPLITUDE**, **More**, **Y-Axis Units**, **dBm**.
5. Set the resolution bandwidth to spectrum analyzer coupling by pressing **BW/Avg**, **Res BW (SA)**.
6. Set the center frequency of the analyzer to 400 MHz by pressing **FREQUENCY**, **Center Freq**, **400**, **MHz**.
7. Set the span to 500 MHz by pressing **SPAN**, **Span**, **500**, **MHz**.

The signal produces harmonic distortion products in the analyzer input mixer as shown in [Figure 1-34](#).

Figure 1-34 Harmonic Distortion

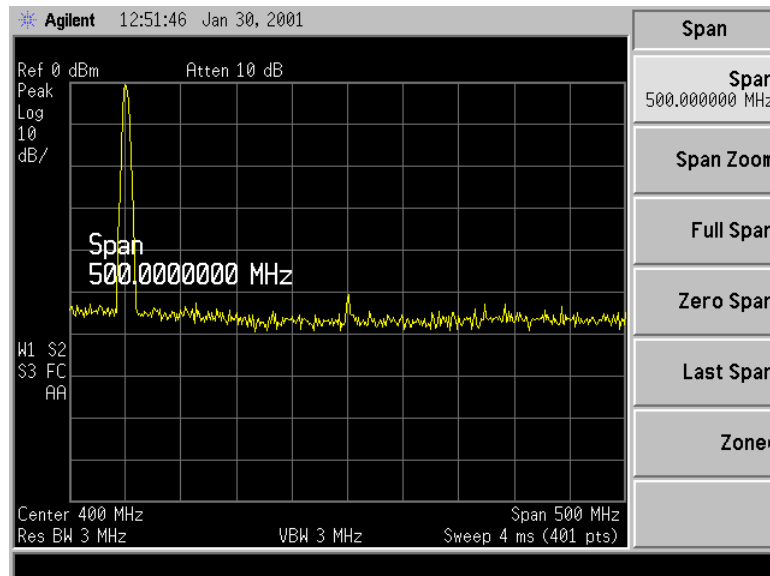

8. Change the center frequency to the value of one of the observed harmonics by pressing **Peak Search**, **Next Peak**, **Marker**→, **Mkr**→**CF**.
9. Change the span to 50 MHz: press **SPAN**, **Span**, **50**, **MHz**.
10. Ensure that the signal is still at the center frequency, if necessary press **Peak Search**, **Marker**→, **Mkr**→**CF**.
11. Change the attenuation to 0 dB: press **AMPLITUDE**, **Attenuation**, **0**, **dBm**. Your display should be similar to [Figure 1-35](#).

Figure 1-35 Harmonic Distortion with 0 dB Attenuation

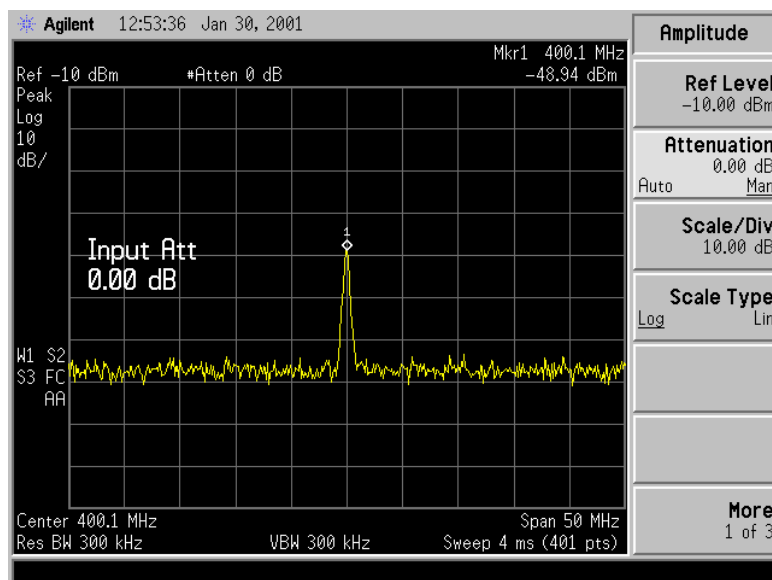

12. To determine whether the harmonic distortion products are generated by the analyzer, first save the screen data in trace 2 as follows:
 - a. Press **Trace/View, Trace (2)**, then **Clear Write**.
 - b. Allow the trace to update (two sweeps) and press **Trace/View, View, Marker, Delta**. The analyzer display shows the stored data in trace 2 and the measured data in trace 1.
13. Next, increase the RF attenuation by 10 dB: press **AMPLITUDE, Attenuation**, and the step-up key (\uparrow) twice. See [Figure 1-36](#).

Notice the $\Delta Mkr1$ amplitude reading. This is the difference in the distortion product amplitude readings between 0 dB and 10 dB input attenuation settings. If the $\Delta Mkr1$ amplitude absolute value is approximately ≥ 1 dB for an input attenuator change, the distortion is being generated, at least in part, by the analyzer. In this case more input attenuation is necessary.

Figure 1-36 RF Attenuation of 10 dB

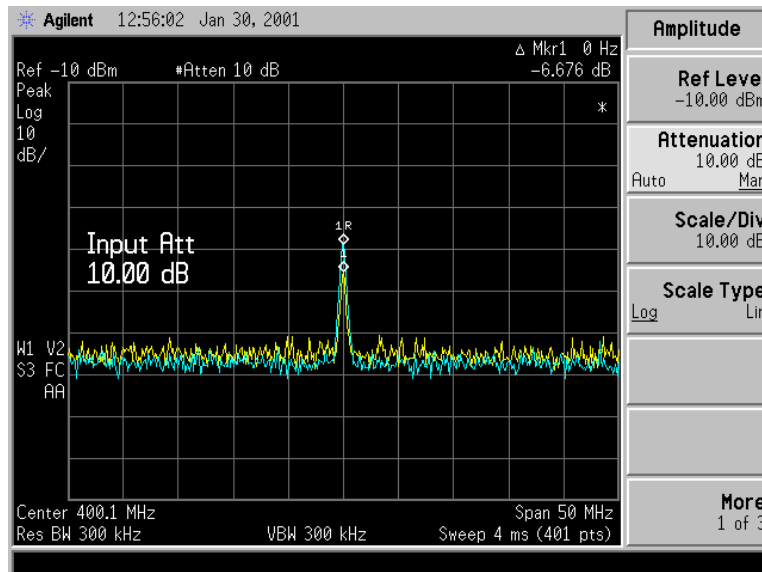

14. Press **Peak Search, Marker, Delta**

Change the attenuation to 15 dB by pressing **Attenuation, 15, dB**.

If the $\Delta Mkr1$ amplitude absolute value is approximately ≥ 1 dB as seen in [Figure 1-36](#), then more input attenuation is required; some of the measured distortion is internally generated. If there is no change in the signal level, the distortion is not generated internally. For example, the signal that is causing the distortion shown in [Figure 1-37](#) is not high enough in amplitude to cause internal distortion in the analyzer so any distortion that is displayed is present on the input signal.

Figure 1-37 No Harmonic Distortion

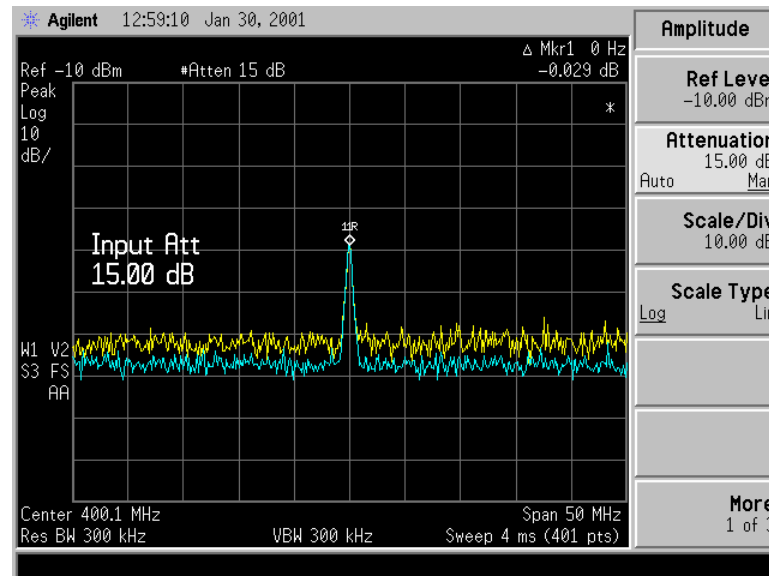

Third-Order Intermodulation Distortion

Two-tone, third-order intermodulation distortion is a common test in communication systems. When two signals are present in a non-linear system, they can interact and create third-order intermodulation distortion products that are located close to the original signals. These distortion products are generated by system components such as amplifiers and mixers.

Identifying TOI Distortion Example:

Test a device for third-order intermodulation. This example uses two sources, one set to 300 MHz and the other to approximately 301 MHz. (Other source frequencies may be substituted, but try to maintain a frequency separation of approximately 1 MHz.)

1. Connect the equipment as shown in [Figure 1-38](#). This combination of signal generators, low pass filters, and directional coupler (used as a combiner) results in a two-tone source with very low intermodulation distortion. Although the distortion from this setup may be better than the specified performance of the analyzer, it is useful for determining the TOI performance of the source/analyzer combination. After the performance of the source/analyzer combination has been verified, the device-under-test (DUT) (for example, an amplifier) would be inserted between the directional coupler output and the analyzer input and another measurement would be made.

Figure 1-38 Third-Order Intermodulation Equipment Setup

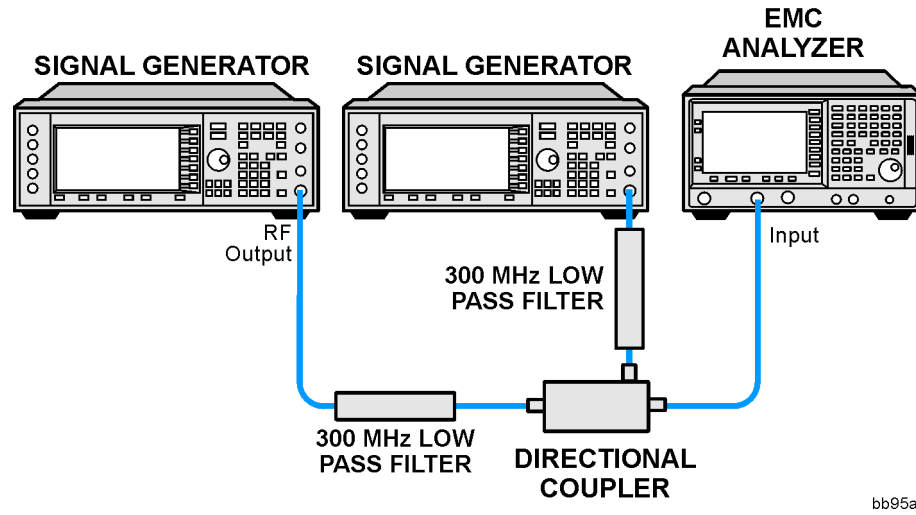

NOTE

The combiner should have a high degree of isolation between the two input ports so the sources do not intermodulate.

2. Set one source (signal generator) to 300 MHz and the other source to 301 MHz, for a frequency separation of 1 MHz. Set the sources equal in amplitude as measured by the analyzer (in this example, they are set to -5 dBm).
3. On the analyzer, perform a factory preset by pressing **Preset, Factory Preset** (if present).
4. Set the Y-Axis Units to dBm by pressing **AMPLITUDE, More, Y-Axis Units, dBm**.
5. Set the resolution bandwidth to spectrum analyzer coupling by pressing **BW/Avg, Res BW (SA)**.
6. Set the span to 5 MHz by pressing **SPAN, Span, 5, MHz**. This is wide enough to include the distortion products on the screen.
7. Tune both test signals onto the screen by setting the center frequency 300.5 MHz, press **FREQUENCY, Center Freq, 300.5, MHz**.
If necessary, use the front-panel knob to center the two test signals on the display.
8. To be sure the distortion products are resolved, reduce the resolution bandwidth until the distortion products are visible by pressing **BW/Avg, Res BW**, and then use the step-down key (\downarrow) to reduce the resolution bandwidth until the distortion products are visible.
9. For best dynamic range, set the maximum mixer input level to -30 dBm and move the signal to the reference level: press **AMPLITUDE, More, Max Mixer Lvl, -30 , dBm**.

The analyzer automatically sets the attenuation so that a signal at the reference level will be a maximum of -30 dBm at the input mixer.

10. Press **BW/Avg, Res BW**, and then use the step-down key (\downarrow) to reduce the resolution bandwidth until the distortion products are visible.
11. To measure a distortion product, press **Peak Search** to place a marker on a source signal.
12. Set the marked signal to the reference level by pressing **Mkr \rightarrow** and then **Mkr \rightarrow Ref Lvl**.
13. To activate the second marker, press **Marker, Delta, Peak Search**. Using the **Next Peak** key to place the second marker on the peak of the distortion product that is beside the test signal. The difference between the markers is displayed in the active function area. See [Figure 1-39](#).

Figure 1-39 Measuring the Distortion Product

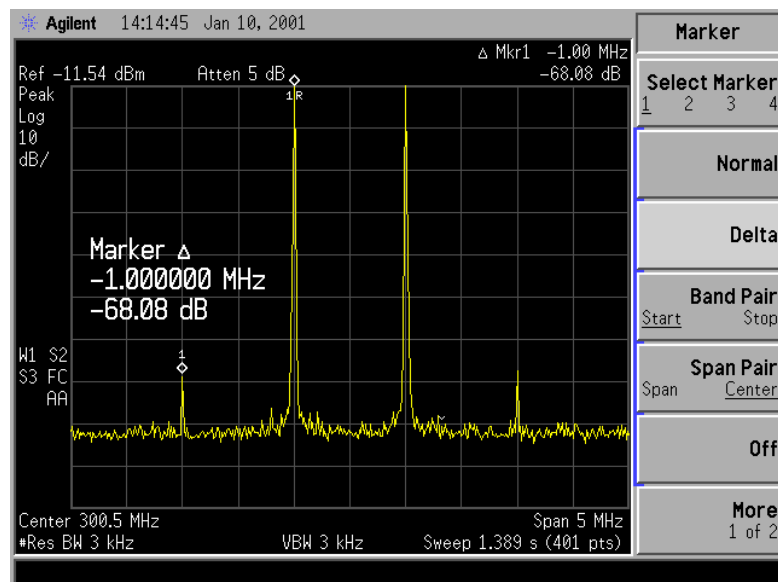

14. To measure the other distortion product, press **Marker, Normal, Peak Search, Next Peak**. This places a marker on the next highest peak, the other source signal.
15. To measure the difference between this test signal and the second distortion product, press **Delta, Peak Search**. Using the **Next Peak** key to place the second marker on the peak of the second distortion product. See [Figure 1-40](#).

Figure 1-40 Measuring the Distortion Product

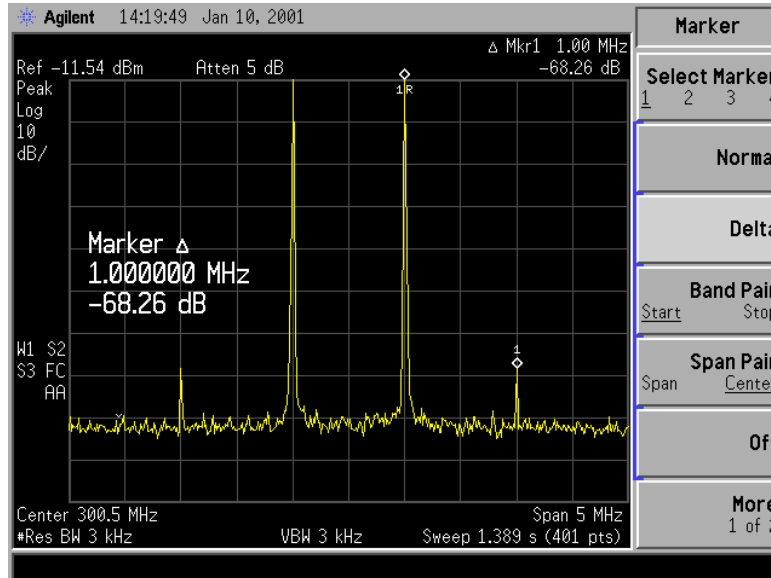

Measuring Signal-to-Noise

The signal-to-noise measurement procedure below may be adapted to measure any signal in a system if the signal (carrier) is a discrete tone. If the signal in your system is modulated, it will be necessary to modify the procedure to correctly measure the modulated signal level

In this example the 50 MHz amplitude reference signal is used as the fundamental source. The amplitude reference signal is assumed to be the signal of interest and the internal noise of the analyzer is measured as the system noise. To do this, you will need to set the input attenuator such that both the signal and the noise are well within the calibrated region of the display.

Signal-to-Noise Measurement Example:

Perform the steps below to measure the signal-to-noise.

1. Perform a factory preset by pressing **Preset, Factory Preset** (if present).
2. Turn on the internal 50 MHz amplitude reference signal of the analyzer as follows:
 - For the E7401A, use the internal 50 MHz amplitude reference signal of the analyzer as the signal being measured. Press **Input/Output, Amptd Ref (On)**.
 - For all other models connect a cable between the front-panel AMPTD REF OUT to the analyzer INPUT, then press **Input/Output, Amptd Ref Out (On)**.
3. Set the center frequency to 50 MHz by pressing **FREQUENCY, Center Freq, 50, MHz**.
4. Set the span to 1 MHz by pressing **SPAN, Span, 1, MHz**.
5. Set the Y-Axis Units to dBm by pressing **AMPLITUDE, More, Y-Axis Units, dBm**.
6. Set the resolution bandwidth to spectrum analyzer coupling by pressing **BW/Avg, Res BW (SA)**.
7. Set the reference level to -10 dBm by pressing **AMPLITUDE, Ref Level, -10, dBm**.
8. Set the attenuation to 40 dB by pressing **AMPLITUDE, Attenuation, 40, dB**.
9. Press **Peak Search** to place a marker on the peak of the signal.
10. Press **Marker, Delta, 200, kHz** to put the delta marker in the noise at the specified offset, in this case 200 kHz.

11. Press **More**, **Function**, **Marker Noise** to view the results of the signal to noise measurement. See [Figure 1-41](#).

Figure 1-41 Measuring the Signal-to-Noise

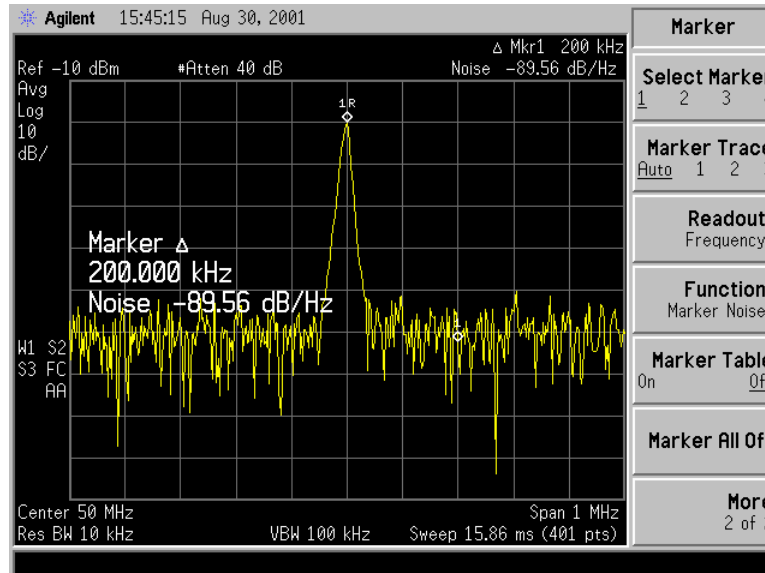

Read the signal-to-noise in dB/Hz, that is with the noise value determined for a 1 Hz noise bandwidth. If you wish the noise value for a different bandwidth, decrease the ratio by $10 \times \log(BW)$. For example, if the analyzer reading is -70 dB/Hz but you have a channel bandwidth of 30 kHz:

$$S/N = -70 \text{ dB/Hz} + 10 \times \log(30 \text{ kHz}) = -25.23 \text{ dB}/(30 \text{ kHz})$$

Note that the display detection mode is now average. If the delta marker is within half a division of the response to a discrete signal, the amplitude reference signal in this case, there is a potential for error in the noise measurement. See [“Making Noise Measurements” on page 51](#).

Making Noise Measurements

There are a variety of ways to measure noise power. The first decision you must make is whether you want to measure noise power at a specific frequency or the total power over a specified frequency range, for example over a channel bandwidth.

Noise Measurement Example 1:

Using the marker function, **Marker Noise**, is a simple method to make a measurement at a single frequency. In this example, attention must be made to the potential errors due to discrete signal (spectral components). This measurement will be made near the 50 MHz amplitude reference signal to illustrate the use of **Marker Noise**.

1. Perform a factory preset by pressing **Preset, Factory Preset** (if present).
2. Turn on the internal 50 MHz amplitude reference signal of the analyzer as follows:
 - For the E7401A, use the internal 50 MHz amplitude reference signal of the analyzer as the signal being measured. Press **Input/Output, Amptd Ref (On)**.
 - For all other models connect a cable between the front-panel AMPTD REF OUT to the analyzer INPUT, then press **Input/Output, Amptd Ref Out (On)**.
3. Set the center frequency to 49.98 MHz by pressing **FREQUENCY, Center Freq, 49.98, MHz**.
4. Set the span to 100 kHz by pressing **SPAN, Span, 100, kHz**.
5. Set the resolution bandwidth to 1 kHz by pressing **BW/Avg, Res BW (Man), 1, kHz**.
6. Set the Y-Axis Units to dBm by pressing **AMPLITUDE, More, Y-Axis Units, dBm**.
7. Set the attenuation to 60 dB by pressing **AMPLITUDE, Attenuation (Man), 60, dB**. See [Figure 1-42](#).

NOTE

When making noise measurements and **AMPLITUDE, Scale Type (Log)** is selected (10 dB/division), position the trace between 3 and 6 graticule lines above the bottom by adjusting the reference level (**AMPLITUDE, Ref Level**). Measurement inaccuracies may occur if displayed trace is positioned outside this range.

Figure 1-42 Setting the Attenuation

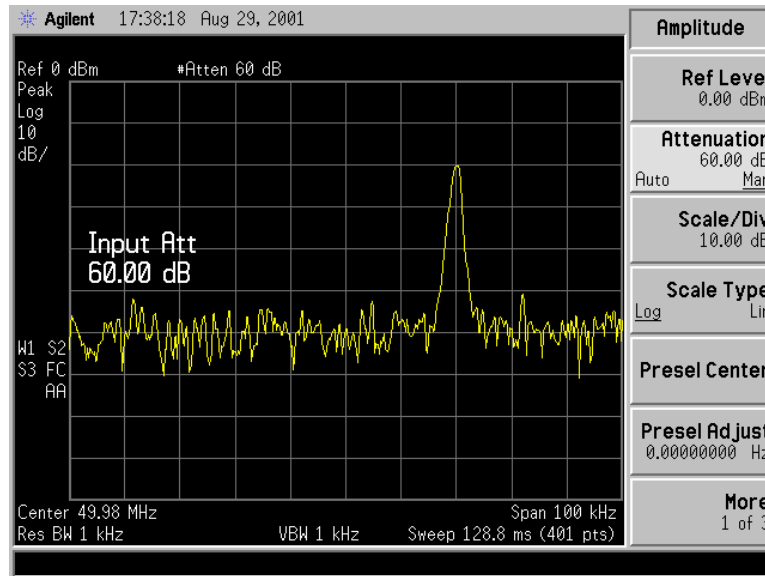

8. Activate the noise marker by pressing **Marker, More, Function, Marker Noise**.

Note that the display detection automatically changed to “Avg” which can be manually set by pressing **Det/Demod, Average (Video/RMS)**. The marker is floating between the maximum and the minimum of the noise. For firmware revisions earlier than A.08.00, the detection type when using **Marker Noise** changed to sample. If you wish to use sample detection, press **Det/Demod, Detector, Sample** and verify that “Average Type” is set to “Video average” by pressing **BW/Avg, Average Type, Video Avg**. This is not recommended as it is slower and does not increase accuracy.

The marker readout is in dBm(Hz) or dBm per unit bandwidth. See [Figure 1-43](#). For noise power in a different bandwidth, add $10 \times \log(\text{BW})$. For example, for noise power in a 1 kHz bandwidth, add $10 \times \log(1000)$ or 30 dB to the noise marker value.

Figure 1-43 Activating the Noise Marker

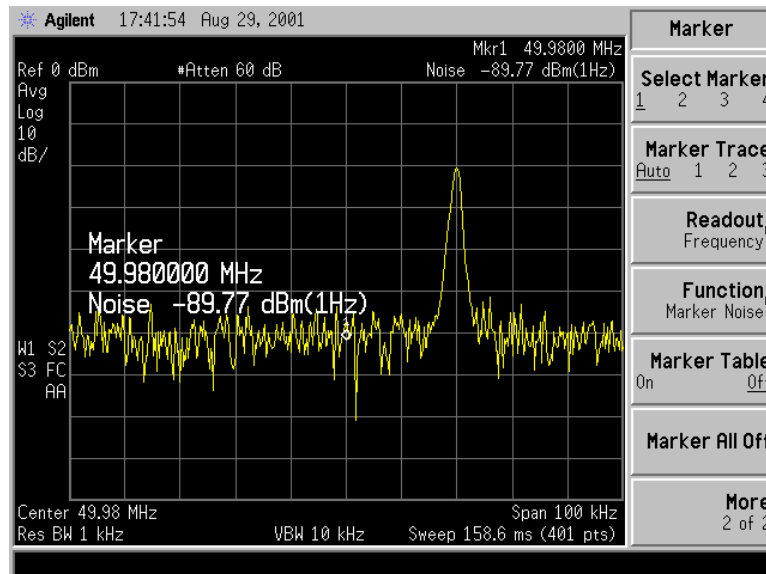

- The noise marker value is based on the mean of 5% of the total number of sweep points centered at the marker. The points averaged span one-half of a division. To see the effect, move the marker to the 50 MHz signal by pressing **Marker, 50, MHz** (or use the front-panel knob to place marker at 50 MHz). See [Figure 1-44](#).

Figure 1-44 Noise Marker at 50 MHz

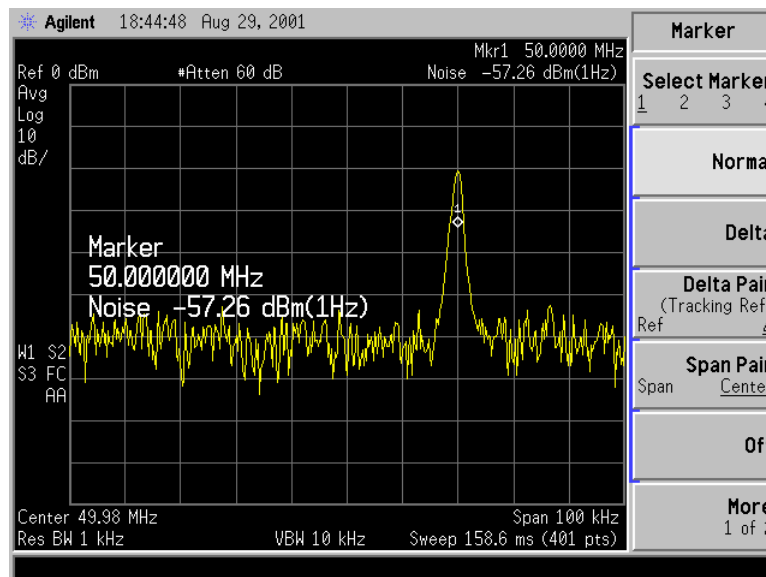

- The marker does not go to the peak of the signal because not all averaged points are at the peak of the signal. Widen the resolution bandwidth by pressing **BW/Avg, Res BW, 10, kHz** (or up arrow) to see what happens. The marker is now much closer to the peak of the signal. See [Figure 1-45](#).

NOTE

Notice the video bandwidth changed to 100 kHz. The ratio between the video bandwidth (VBW) and the resolution bandwidth (RBW) must be $\geq 10/1$ to maintain the accuracy of the measurement.

Figure 1-45 Increased Resolution Bandwidth

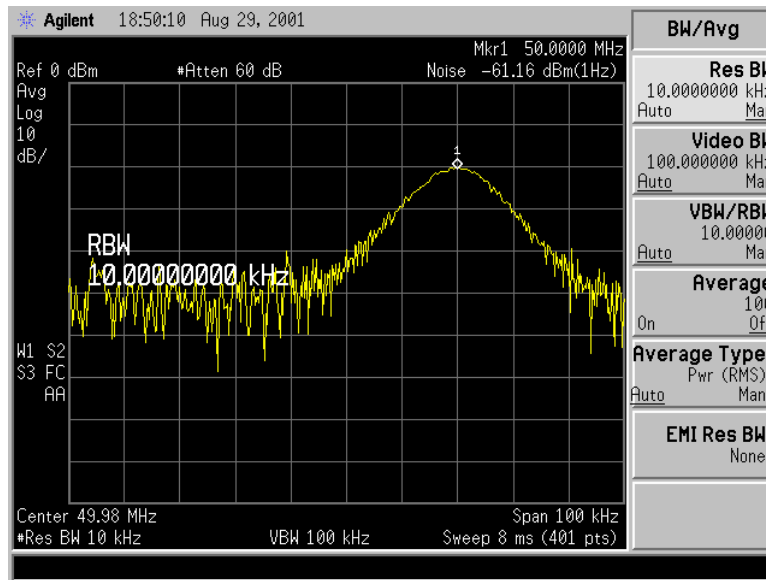

11. Return the resolution bandwidth to 1 kHz. Press **BW/Avg**, **1, kHz**.
12. Measure the noise very close to the signal by pressing **Marker**, **50.0000, MHz** (or use the front-panel knob to place the marker). See [Figure 1-46](#).

Note that the marker reads a value that is too high because some of the averaged trace points are on the skirt of the signal response.

Figure 1-46 Noise Marker in Signal Skirt

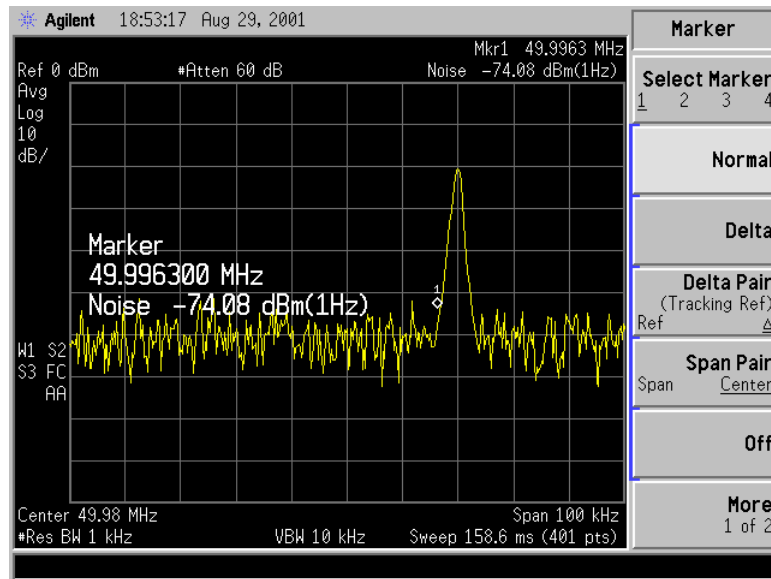

- Set the analyzer to zero span at the marker frequency by pressing **Mkr** →, **Mkr** → **CF**, **SPAN**, **Zero Span**, **Marker**. Note that the marker amplitude value is now correct since all points averaged are at the same frequency and not influenced by the shape of the bandwidth filter. See [Figure 1-47](#).

Figure 1-47 Noise Marker with Zero Span

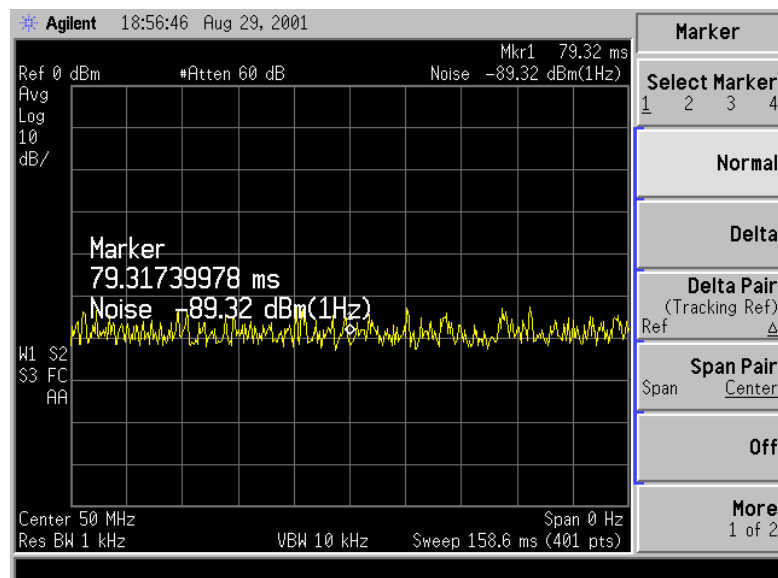

Noise Measurement Example 2:

The Normal marker can also be used to make a single frequency measurement as described in the previous example, again using video filtering or averaging to obtain a reasonably stable measurement. While video averaging automatically selects the sample display detection mode, video filtering does not. With sufficient filtering that results in a smooth trace, there is no difference between the sample and peak modes because the filtering takes place before the signal is digitized.

Be sure to account for the fact that the averaged noise is displayed approximately 2 dB too low for a noise bandwidth equal to the resolution bandwidth. Therefore, you must add 2 dB to the marker reading. For example, if the marker indicates -100 dBm, the actual noise level is -98 dBm.

Noise Measurement Example 3:

You may use adjustable markers to set the frequency span over which power is measured. The markers allow you to easily and conveniently select any arbitrary portion of the displayed signal for measurement. However, while the analyzer does select the average (video/rms) display detection mode, you must set all of the other parameters.

1. Reset the analyzer by pressing **Preset, Factory Preset** (if present).
2. Tune the analyzer to the frequency of 50 MHz. In this example we are using the amplitude reference signal. Press **FREQUENCY, 50, MHz**.
3. Set the span to 100 kHz by pressing **SPAN, 100, kHz**.
4. Set the Y-Axis Units to dBm by pressing **AMPLITUDE, More, Y-Axis Units, dBm**.
5. Set the resolution bandwidth to 1 kHz by pressing **BW/Avg, Resolution BW, 1, kHz**.
6. Set the reference level to -20 dBm by pressing **AMPLITUDE, Ref Level, -20 , dBm**.
7. Set the input attenuator to 40 dB by pressing **Attenuation, 40, dB**.
8. Set the marker span to 40 kHz by pressing **Marker, Span Pair (Span), 40, kHz**.

The resolution bandwidth should be about 1 to 3% of the measurement (marker) span, 40 kHz in this example. The 1 kHz resolution bandwidth that the analyzer has chosen is fine. The video bandwidth should be ten times wider.

9. Set the video bandwidth to 10 kHz by pressing **BW/Avg, Video BW (Man), 10, kHz**.

10. Measure the power between markers by pressing **Marker, More, Function, Band Power**. The analyzer displays the total power between the markers. See [Figure 1-48](#).
11. Add a discrete tone to see the effects of the reading. Turn on the internal 50 MHz amplitude reference signal of the analyzer (if you have not already done so) as follows:
 - For the E7401A, use the internal 50 MHz amplitude reference signal of the analyzer as the signal being measured. Press **Input/Output, Amptd Ref (On)**.
 - For all other models connect a cable between the front-panel AMPTD REF OUT to the analyzer INPUT, then press **Input/Output, Amptd Ref Out (On)**.

Figure 1-48 Viewing Power Between Markers

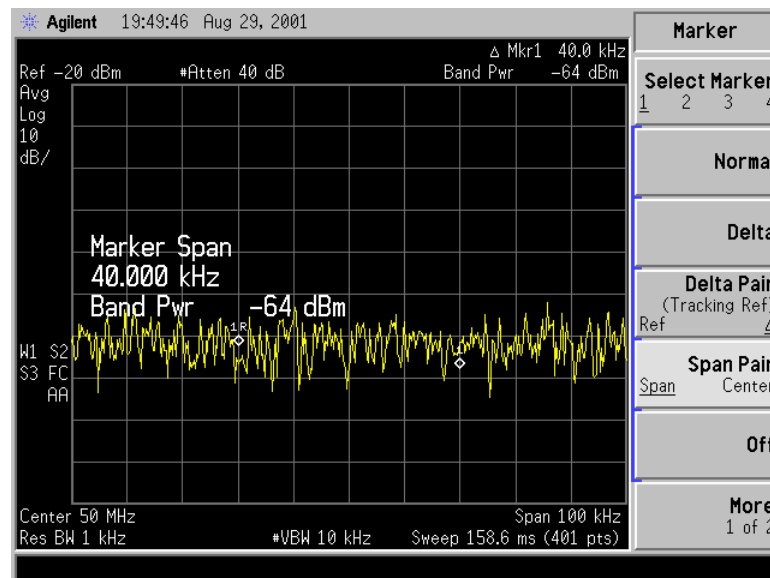

12. Move the measured span by pressing **Marker, Span Pair (Center)**. Then use the knob to exclude the tone and note reading. You could have also used **Band Pair** or **Delta Pair** to set the measurement start and stop points independently. See [Figure 1-49](#).

Figure 1-49 Measuring the Power in the Span

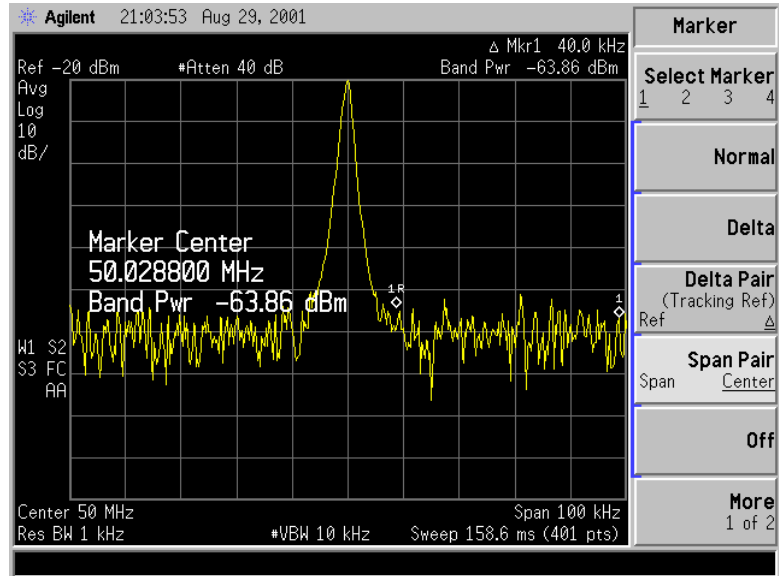

Demodulating AM Signals (Using the Analyzer As a Fixed Tuned Receiver)

The zero span mode can be used to recover amplitude modulation on a carrier signal. The analyzer operates as a fixed-tuned receiver in zero span to provide time domain measurements.

Center frequency in the swept-tuned mode becomes the tuned frequency in zero span. The horizontal axis of the screen becomes calibrated in time only, rather than both frequency and time. Markers display amplitude and time values.

The following functions establish a clear display of the waveform:

- Trigger stabilizes the waveform trace on the display by triggering on the modulation envelope. If the modulation of the signal is stable, video trigger synchronizes the sweep with the demodulated waveform.
- Linear mode should be used in amplitude modulation (AM) measurements to avoid distortion caused by the logarithmic amplifier when demodulating signals.
- Sweep time adjusts the full sweep time from 5 ms to 2000 s. (20 μ s to 2000 s if Option AYX is installed). The sweep time readout refers to the full 10-division graticule. Divide this value by 10 to determine sweep time per division.
- Resolution and video bandwidth are selected according to the signal bandwidth.

Each of the coupled function values remains at its current value when zero span is activated. Video bandwidth is coupled to resolution bandwidth. Sweep time is not coupled to any other function.

NOTE

Refer to [“Demodulating and Listening to an AM Signal” on page 88](#) for more information on signal demodulation.

To obtain an AM signal, you can either connect a source to the analyzer input and set the source for amplitude modulation, or connect an antenna to the analyzer input and tune to a commercial AM broadcast station.

Demodulating an AM Signal Example 1:

View the modulation waveform of an AM signal in the time domain.

1. Connect an RF signal source to the analyzer INPUT. For this example, an Agilent E4433B Signal Generator was used with the following settings:
 - a. RF Frequency 300 MHz

- b. RF Output Power -10 dBm
 - c. AM On
 - d. AM Rate 1 kHz
 - e. AM Depth 80%
2. Set the analyzer as follows:
 - a. Press **Preset**, **Factory Preset** (if present).
 - b. Set the center frequency to 300 MHz by pressing **FREQUENCY**, **Center Freq**, **300**, **MHz**.
 - c. Set the span to 500 kHz by pressing **SPAN**, **Span**, **500**, **kHz**.
 - d. Set the resolution bandwidth to 30 kHz by pressing **BW/Avg**, **Resolution BW**, **30**, **kHz**.
 - e. Set the Y-Axis Units to dBm by pressing **AMPLITUDE**, **More**, **Y-Axis Units**, **dBm**.
 - f. Change the analyzer sweep to 20 msec by pressing **Sweep**, **Sweep Time**, **20**, **ms**. See [Figure 1-50](#).

Figure 1-50 Viewing an AM Signal

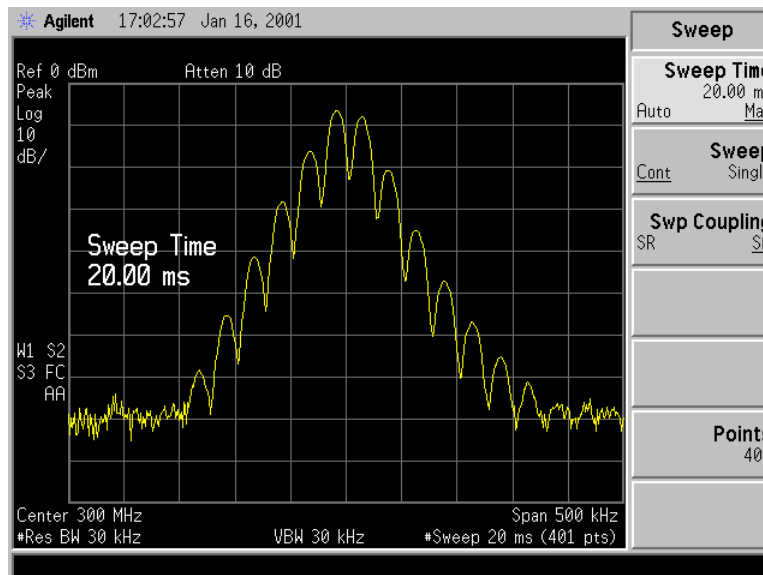

3. Set the Y-Axis Units to V by pressing **AMPLITUDE**, **More**, **Y-Axis Units**, **V**.
4. Position the signal peak near the reference level by pressing **AMPLITUDE** and rotating the front-panel knob.
5. Change the amplitude scale type to linear by pressing **AMPLITUDE**, **Scale Type (Lin)**.

6. Select zero span by either pressing **SPAN, 0, Hz**; or pressing **SPAN, Zero Span**. See [Figure 1-51](#).
7. Change the sweep time to 5 ms by pressing **Sweep, Sweep Time (Man), 5, ms**.
8. Since the modulation is a steady tone, you can use video trigger to trigger the analyzer sweep on the waveform and stabilize the trace, much like an oscilloscope by pressing **Trig, Video**, and adjusting the trigger level with the front-panel knob until the signal stabilizes. See [Figure 1-52](#).

If you are viewing an off-the-air signal you will not be able to stabilize the waveform.

NOTE

If the Trigger Level is set too high or too low when this trigger mode is activated, the sweep will stop. You will need to adjust the trigger level up or down with the front-panel knob until the sweep begins again.

Figure 1-51 Measuring Modulation In Zero Span

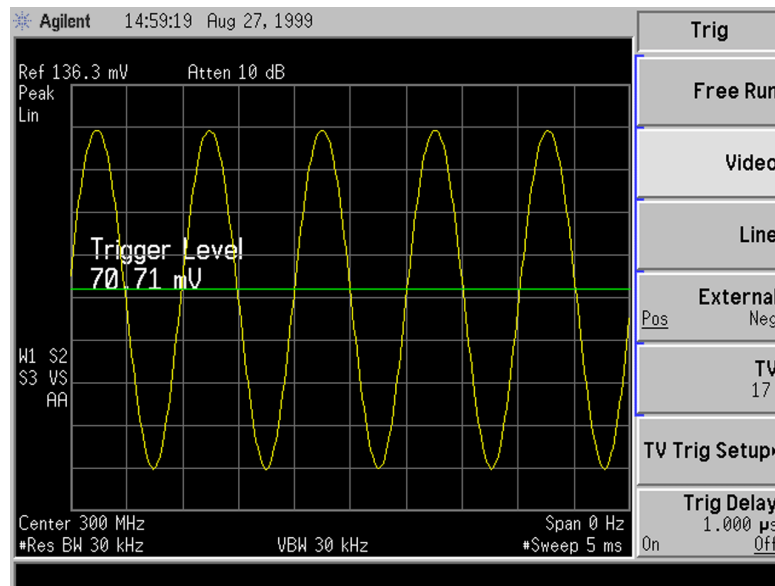

Figure 1-52 Measuring Modulation In Zero Span

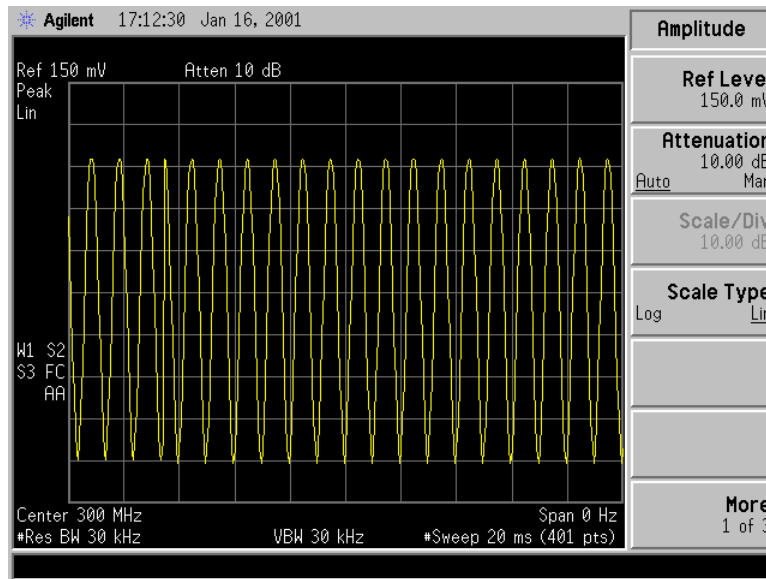
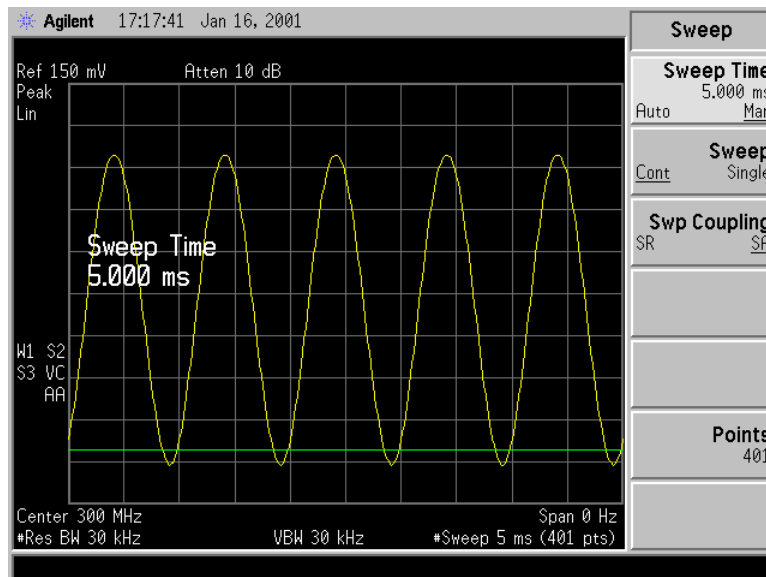
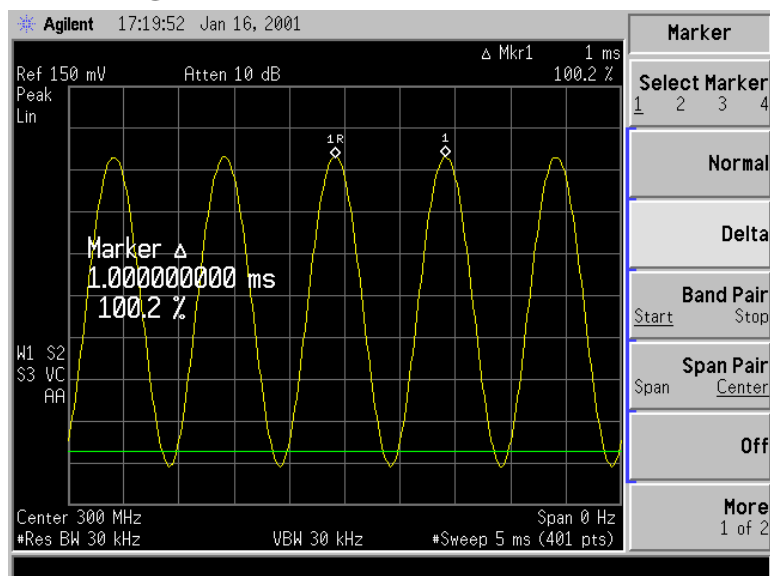

Figure 1-53 Measuring Modulation In Zero Span



9. Use markers and delta markers to measure the time parameters of the waveform.
 - a. Press **Marker** and center the marker on a peak using **Peak Search** or the front-panel knob.
 - b. Press **Marker, Delta** and center the marker on the next peak using the front-panel knob or use **Peak Search** and **Next Pk Right** (or **Next Pk Left**). See [Figure 1-54](#).

Figure 1-54 Measuring Time Parameters



10. You can turn your analyzer into a % AM indicator as follows:

- a. Set trigger to free run by pressing **Trig, Free Run**.
- b. Set the sweep time to 5 seconds by pressing **Sweep, Sweep Time, 5, s**.
- c. Set the video filter to 30 Hz by pressing **BW/Avg, Video BW, 30, Hz**.
- d. Change the reference level to position the trace at midscreen by pressing **AMPLITUDE, Ref Level**, and adjacent the reference level using the front-panel knob.
- e. Reset the video filter to a high value. For example, press **BW/Avg, Video BW, 100, kHz**.
- f. Set the sweep time to 5 milliseconds by pressing **Sweep, Sweep Time, 5, ms**.

The center horizontal line of the graticule now represents 0% AM; the top and bottom lines, 100% AM. See [Figure 1-55](#).

Figure 1-55 Continuous Demodulation of an AM Signal

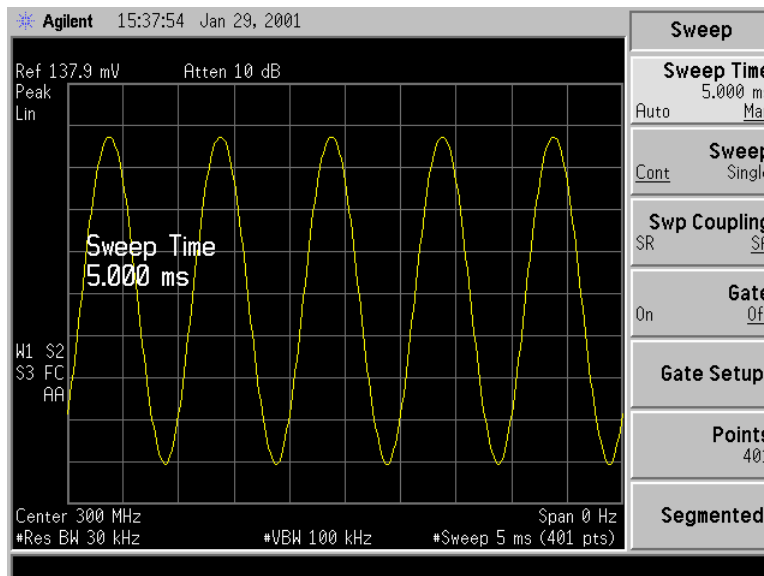

Demodulating FM Signals

As with amplitude modulation (see [page 59](#)) you can utilize zero span to demodulate an FM signal. However, unlike the AM case, you cannot simply tune to the carrier frequency and widen the resolution bandwidth. The reason is that the envelope detector in the analyzer responds only to amplitude variations, and there is no change in amplitude if the frequency changes of the FM signal are limited to the flat part of the resolution bandwidth.

On the other hand, if you tune the analyzer slightly away from the carrier, you can utilize slope detection to demodulate the signal by performing the following steps.

1. Determine the correct resolution bandwidth.
2. Find the center of the linear portion of the filter skirt (either side).
3. Tune the analyzer to put the center point at mid screen of the display.
4. Select zero span.

The demodulated signal is now displayed; the frequency changes have been translated into amplitude changes., see [Figure 1-58](#). To listen to the signal, turn on AM demodulation and the speaker.

In this example you will demodulate a broadcast FM signal that has a specified 75 kHz peak deviation.

Demodulating a FM Signal Example:

Determine the correct resolution bandwidth. With a peak deviation of 75 kHz, your signal has a peak-to-peak excursion of 150 kHz. So we must find a resolution bandwidth filter with a skirt that is reasonably linear over that frequency range.

1. Perform a factory preset by pressing **Preset, Factory Preset** (if present).
2. Turn on the internal 50 MHz reference signal of the analyzer as follows:
 - For the E7401A, use the internal 50 MHz amplitude reference signal of the analyzer as the signal being measured. Press **Input/Output, Amptd Ref (On)**.
 - For all other models connect a cable between the front-panel **AMPTD REF OUT** to the analyzer **INPUT**, then press **Input/Output, Amptd Ref Out (On)**.
3. Set the center frequency to 50 MHz by pressing **FREQUENCY, Center Freq, 50, MHz**.

4. Set the span to 1 MHz by pressing **SPAN, Span, 1, MHz**.
5. Set the Y-Axis Units to dBm by pressing **AMPLITUDE, More, Y-Axis Units, dBm**.
6. Set the reference level to -20 dBm by pressing **AMPLITUDE, Ref Level, -20, dBm**.
7. Set the resolution bandwidth to 100 kHz by pressing **BW/Avg, Res BW, 100, kHz**. The skirt is reasonably linear starting approximately 5 dB below the peak.
8. Select a marker by pressing **Marker**, then move the marker approximately 1/2 division down the right of the peak (high frequency) using the front-panel knob.
9. Place a delta marker 150 kHz from the first marker by pressing **Delta, 150, kHz**. The skirt looks reasonably linear between markers.
10. Determine the offset from the signal peak to the desired point on the filter skirt by moving the delta marker to the midpoint. Press **75, kHz** to move the delta marker to the midpoint. See [Figure 1-56](#).

Figure 1-56 Establishing the Offset Point

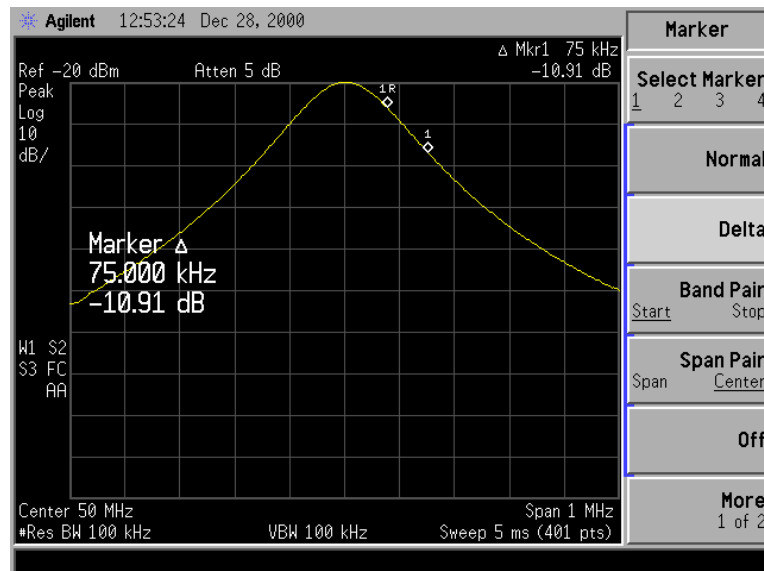

11. Press **Delta** to make the active marker the reference marker.
12. Press **Peak Search** to move the delta marker to the peak. The delta value is the desired offset, for example 151 kHz. See [Figure 1-57](#).

Figure 1-57 Determining the Offset

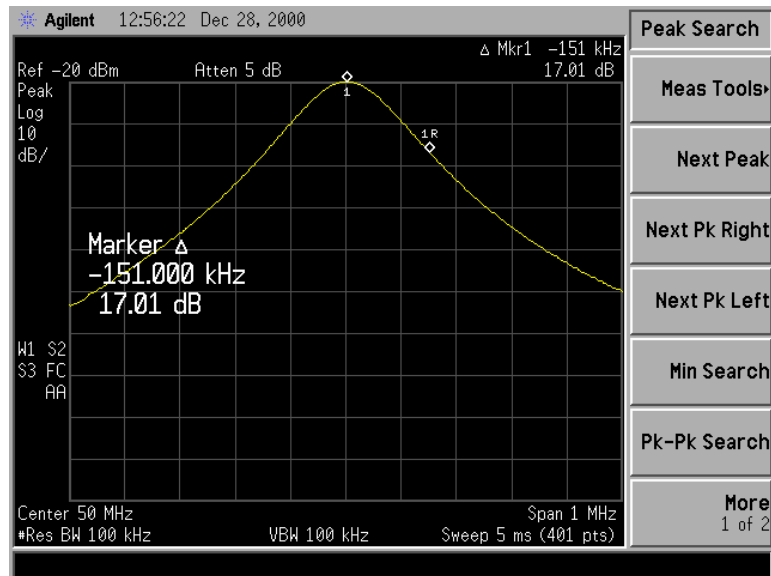

Demodulate the FM Signal

1. Connect an antenna to the analyzer INPUT.
2. Perform a factory preset by pressing **Preset, Factory Preset** (if present).
3. Tune the analyzer to a peak the peak of one of your local FM broadcast signals, for example 97.7 MHz by pressing **FREQUENCY, Center Freq, 97.7, MHz**.
4. Set the span to 1 MHz by pressing **SPAN, Span, 1, MHz**.
5. Press **AMPLITUDE, Ref Level**, and use the front-panel knob to bring the signal peak to the reference level.
6. Press **Scale Type (Lin)** to place the analyzer in linear scale mode.
7. Tune above or below the FM signal by the offset noted above in [step 12](#), in this example 151 kHz. Press **FREQUENCY, CF Step, 151, kHz**, then press **Center Freq** and use the step-up key (↑) or step-down key (↓).
8. Set the resolution bandwidth to 100 kHz, by pressing **BW/Avg, Res BW, 100, kHz**.
9. Set the span to zero by pressing **SPAN, Zero Span**.
10. Turn off the automatic alignment by pressing **System, Alignments, Auto Align, Off**.
11. Listen to the demodulated signal through the speaker by pressing **Det/Demod, Demod, AM, Speaker (On)**, then adjust the volume using the front-panel volume knob.

12. Activate single sweep by pressing **Single**. See [Figure 1-58](#).

Figure 1-58 Demodulating a Broadcast Signal

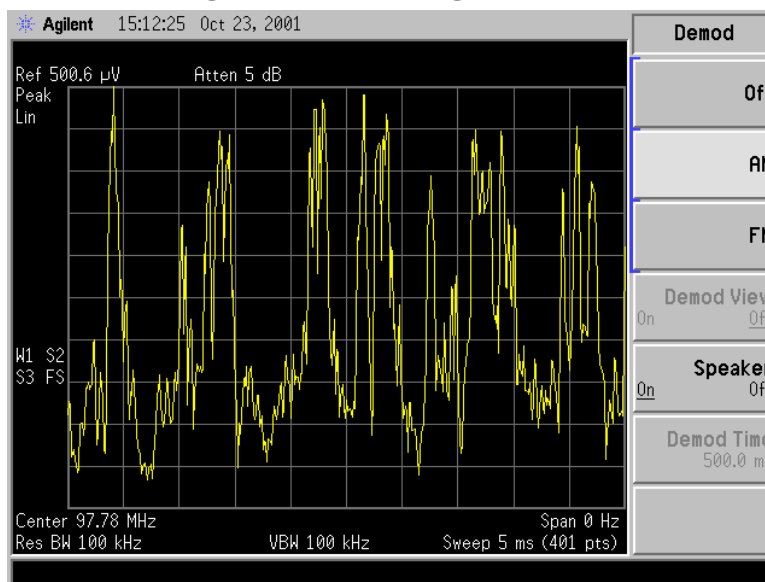

2 Making Complex Measurements

What's in This Chapter

This chapter provides information for making complex measurements. The procedures covered in this chapter are listed below.

- “Making Stimulus Response Measurements” on page 71.
- “Making a Reflection Calibration Measurement” on page 84.
- “Demodulating and Listening to an AM Signal” on page 88.

To find descriptions of specific analyzer functions refer to the *Agilent Technologies EMC Series Analyzers User's Guide*.

Required Test Equipment

Test Equipment	Specifications	Recommended Model
Adapters		
Type-N (m) to BNC (f) (2)		1250-0780
Cables		
(3) BNC, 122-cm (48-in)		10503A
Miscellaneous		
Bandpass Filter	Center Frequency: 200 MHz Bandwidth: 10 MHz	
Lowpass Filter	Cutoff Frequency: 10 MHz	

Making Stimulus Response Measurements

What Are Stimulus Response Measurements?

Stimulus response measurements require a source to stimulate a device under test (DUT), a receiver to analyze the frequency response characteristics of the DUT, and, for return loss measurements, a directional coupler or bridge. Characterization of a DUT can be made in terms of its transmission or reflection parameters. Examples of transmission measurements include flatness and rejection. Return loss is an example of a reflection measurement.

A spectrum analyzer combined with a tracking generator forms a stimulus response measurement system. With the tracking generator as the swept source and the analyzer as the receiver, operation is the same as a single channel scalar network analyzer. The tracking generator output frequency must be made to precisely track the analyzer input frequency for good narrow band operation. A narrow band system has a wide dynamic measurement range. This wide dynamic range will be illustrated in the following example.

Using An Analyzer With A Tracking Generator

There are three basic steps in performing a stimulus response measurement, whether it is a transmission or a reflection measurement. The steps are to set all the analyzer settings, normalize, and measure.

The procedure below describes how to use a built in tracking generator system to measure the rejection of a band pass filter, a type of transmission measurement. Illustrated in this example are functions in the tracking generator menu such as adjusting the tracking generator output power. Normalization functions located in the trace menu are also used. Making a reflection measurement is similar and is covered in [“Making a Reflection Calibration Measurement” on page 84](#).

Stepping Through a Transmission Measurement

1. To measure the rejection of a band pass filter, connect the equipment as shown in [Figure 2-1](#). This example uses a 200 MHz bandpass filter as the DUT.

Figure 2-1 **Transmission Measurement Test Setup**

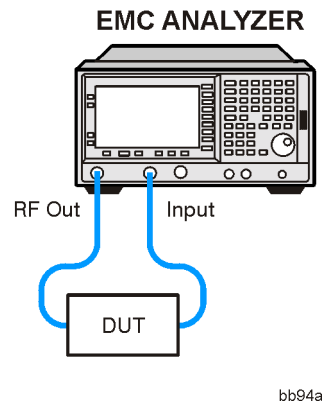

2. Perform a factory preset by pressing **Preset**, **Factory Preset** (if present).
3. Set the Y-Axis Units to dBm by pressing **AMPLITUDE**, **More**, **Y-Axis Units**, **dBm**.
4. Since we are only interested in the rejection of the bandpass filter, tune the analyzer center frequency and span to center the bandpass response and display the rejection ± 50 MHz from the center of the bandpass.
 - a. Set the span to 100 MHz by pressing **SPAN**, **Span**, **100**, **MHz**.
 - b. Set the center frequency to 200 MHz by pressing **FREQUENCY**, **Center Freq**, **200**, **MHz**.
5. Set the resolution bandwidth to 3 MHz by pressing **BW/Avg**, **Res BW**, **3**, **MHz**.
6. Turn on the tracking generator and if necessary, set the output power to -10 dBm by pressing **Source**, **Amplitude (On)**, **-10** , **dBm**. See [Figure 2-2](#).

CAUTION

Excessive signal input may damage the DUT. Do not exceed the maximum power that the device under test can tolerate.

NOTE

To reduce ripples caused by source return loss, use 10 dB (E7401A) or 8 dB (all other models) or greater tracking generator output attenuation. Tracking generator output attenuation is normally a function of the source power selected. However, the output attenuation may be controlled in the **Source** menu. Refer to specifications and characteristics in your specifications guide for more information on the relationship between source power and source attenuation.

Figure 2-2 Tracking Generator Output Power Activated

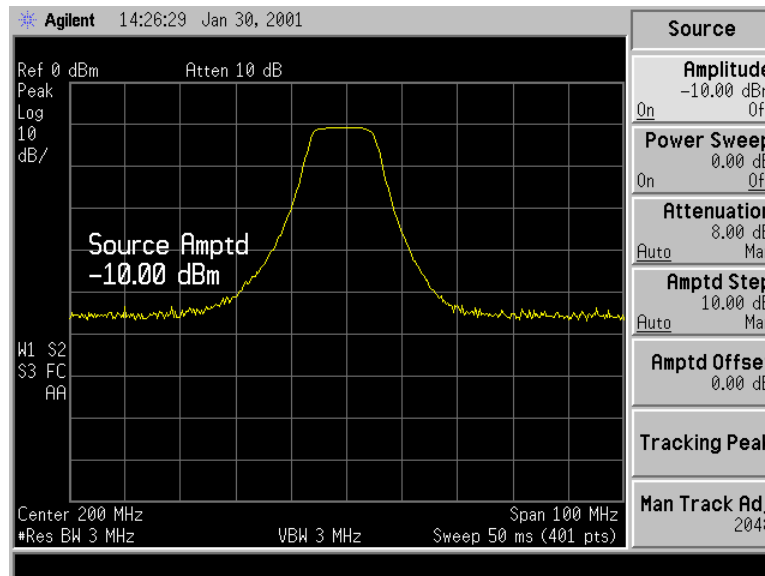

- Put the sweep time of the analyzer into stimulus response auto coupled mode by pressing **Sweep, Swp Coupling (SR)**. Auto coupled sweep times are usually much faster for stimulus response measurements than they are for spectrum analyzer (SA) measurements. If necessary, adjust the reference level to place the signal on screen.

NOTE

In the stimulus response mode, the Q of the DUT can determine the fastest rate at which the analyzer can be swept. (Q is the quality factor, which is the center frequency of the DUT divided by the bandwidth of the DUT.) To determine whether the analyzer is sweeping too fast, slow the sweep and note whether there is a frequency or amplitude shift of the trace. Continue to slow the sweep until there is no longer a frequency or amplitude shift.

- Decrease the resolution bandwidth to increase sensitivity by pressing **BW/Avg, Res BW**, and the step-down key (\downarrow) until the sensitivity is increased. In [Figure 2-3](#), the resolution bandwidth has been decreased to 30 kHz.
- Narrow the video bandwidth to smooth the noise by pressing **BW/Avg, Video BW**, and the step-down key (\downarrow) until the noise is reduced. In [Figure 2-3](#), the video bandwidth has been decreased to 300 Hz.

Figure 2-3 Decrease the Resolution Bandwidth to Improve Sensitivity

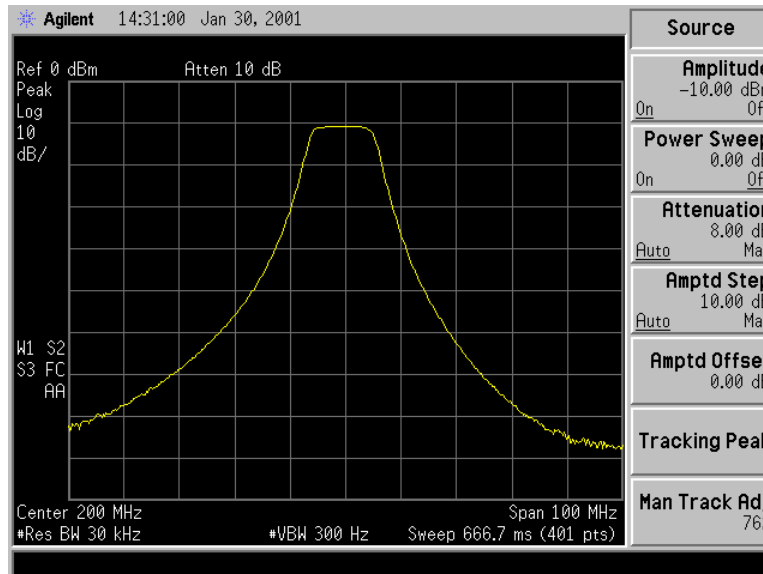

10. You might notice a decrease in the displayed amplitude as the resolution bandwidth is decreased, (if the analyzer is an E7402A, E7403A, E7404A, or E7405A). This indicates the need for performing a tracking peak. Press **Source, Tracking Peak**. The amplitude should return to that which was displayed prior to the decrease in resolution bandwidth.

11. To make a transmission measurement accurately, the frequency response of the test system must be known. Normalization is used to eliminate this error from the measurement. To measure the frequency response of the test system, connect the cable (but not the DUT) from the tracking generator output to the analyzer input. Press **Trace/View, More, Normalize, Store Ref (1→3), Normalize (On)**. The frequency response of the test system is automatically stored in trace 3 and a normalization is performed. This means that the active displayed trace is now the ratio of the input data to the data stored in trace 3. (The reference trace is Trace 3 with firmware revision A.04.00 and later)

When normalization is on, trace math is being performed on the active trace. The trace math performed is (trace 1 – trace 3 + the normalized reference position), with the result placed into trace 1. Remember that trace 1 contains the measurement trace, trace 3 contains the stored reference trace of the system frequency response, and normalized reference position is indicated by arrowheads at the edges of the graticule.

NOTE

Since the reference trace is stored in trace 3, changing trace 3 to Clear Write will invalidate the normalization.

12. Reconnect the DUT to the analyzer. Note that the units of the reference level have changed to dB, indicating that this is now a relative measurement.

Press **Trace/View, More, Normalize, Norm Ref Posn** to change the normalized reference position. Arrowheads at the left and right edges of the graticule mark the normalized reference position, or the position where 0 dB insertion loss (transmission measurements) or 0 dB return loss (reflection measurements) will normally reside. Using the knob results in a change in the position of the normalized trace, within the range of the graticule.

13. To measure the rejection of the filter 45 MHz above the center of the bandpass, press **Marker, 200, MHz** (to ensure that the marker is in the center of the signal), and then press **Delta, 45, MHz**. The marker readout displays the rejection of the filter at 45 MHz above the center of the bandpass. See [Figure 2-4](#).

NOTE

Because the default trace is comprised of 401 discrete points, the indicated marker frequency may differ slightly from the frequency that you entered. Due to the horizontal resolution of the trace, the marker frequency value will be rounded to within 0.25% of the span of the value entered. If the analyzer is an ESA-E series with firmware revision A.04.00 or later, the number of sweep points may be set to any value between 101 and 8192.

Figure 2-4 Measure the Rejection Range

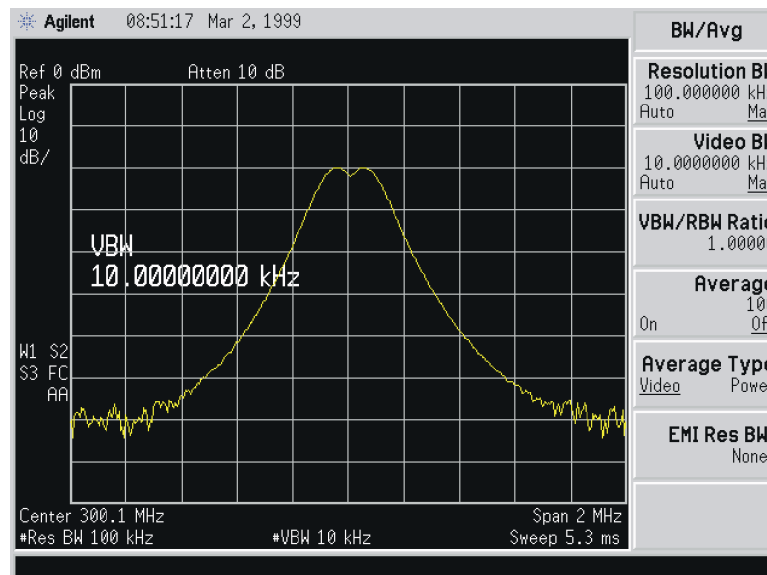

Tracking Generator Unleveled Condition

When using the tracking generator, the message **TG unleveled** may appear. The **TG unleveled** message indicates that the tracking generator source power (**Source, Amplitude**) could not be maintained at the selected level during some portion of the sweep. If the unleveled condition exists at the beginning of the sweep, the message will be displayed immediately. If the unleveled condition occurs after the sweep begins, the message will be displayed after the sweep is completed. A momentary unleveled condition may not be detected when the sweep time is short. The message will be cleared after a sweep is completed with no unleveled conditions.

The unleveled condition may be caused by any of the following:

- Start frequency is too low or the stop frequency is too high. The unleveled condition is likely to occur if the true frequency range exceeds the tracking generator frequency specification (especially the low frequency specification).
- Source attenuation may be set incorrectly (select **Attenuation (Auto)** for optimum setting).
- The source power may be set too high or too low, use **Amplitude (Off)** then **Amplitude (On)** to reset it.
- The source power sweep may be set too high, resulting in an unleveled condition at the end of the sweep. Use **Power Sweep (Off)** then **Power Sweep (On)** to decrease the amplitude.
- Reverse RF power from the device under test detected by the tracking generator ALC (automatic level control) system.

Measuring Device Bandwidth

It is often necessary to measure device bandwidth, such as when testing a bandpass filter. There is a key in the **Peak Search** menu that will perform this function. The device signal being measured must be displayed before activating the measurement. The span must include the full response.

Activate the measurement by toggling the **N dB Points** key to On. The analyzer places arrow markers at the -3 dB points on either side of the response and reads the bandwidth. For other bandwidth responses enter the number of dB down desired, from -1 dB to -80 dB.

No other signal can appear on the display within N dB of the highest signal. The measured signal cannot have more than one peak that is greater than or equal to N dB. A signal must have a peak greater than the currently defined peak excursion to be identified. The default value for the peak excursion is 6 dB.

Measurements are made continuously, updating at the end of each sweep. This allows you to make adjustments and see changes as they happen. The single sweep mode can also be used, providing time to study or record the data.

The N dB bandwidth measurement error is typically $\pm 1\%$ of the span.

Example:

Measure the 3 dB bandwidth of a 200 MHz bandpass filter.

1. To measure the rejection of a bandpass filter, connect the equipment as shown in Figure 2-5. This example uses a 200 MHz bandpass filter.

Figure 2-5 Transmission Measurement Test Setup

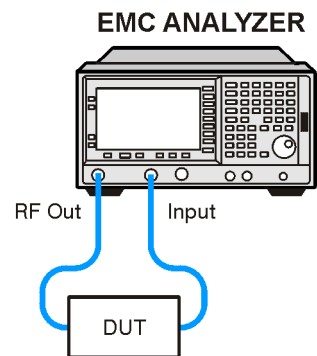

bb94a

2. Perform a factory preset by pressing **Preset, Factory Preset** (if present).
3. Set the Y-Axis Units to dBm by pressing **AMPLITUDE, More, Y-Axis Units, dBm**.
4. Set the span to 100 MHz by pressing **SPAN, Span, 100, MHz**.
5. Set the center frequency to 200 MHz by pressing **FREQUENCY, Center Freq, 200, MHz**.
6. Set the resolution bandwidth to 10 kHz by pressing **BW/Avg, Res BW, 10, kHz**.
7. Turn on the tracking generator and if necessary, set the output power to -10 dBm by pressing **Source, Amplitude (On), -10 , dBm**.

CAUTION

Excessive signal input may damage the DUT. Do not exceed the maximum power that the device under test can tolerate.

NOTE To reduce ripples caused by source return loss, use 10 dB (E7401A) or 8 dB (all other models) or greater tracking generator output attenuation. Tracking generator output attenuation is normally a function of the source power selected. However, the output attenuation may be controlled in the Source menu. Refer to specifications and characteristics in your specifications guide for more information on the relationship between source power and source attenuation.

- Put the sweep time of the analyzer into stimulus response auto coupled mode by pressing **Sweep**, then **Swp Coupling (SR)**. Auto coupled sweep times are usually much faster for stimulus response measurements than they are for spectrum analyzer (SA) measurements. Adjust the reference level if necessary to place the signal on screen.

NOTE In the stimulus response mode, the Q of the DUT can determine the fastest rate at which the analyzer can be swept. (Q is the quality factor, which is the center frequency of the DUT divided by the bandwidth of the DUT.) To determine whether the analyzer is sweeping too fast, slow the sweep and note whether there is a frequency or amplitude shift of the trace. Continue to slow the sweep until there is no longer a frequency or amplitude shift.

- To activate the N dB bandwidth function press **Peak Search**, **More**, then **N dB Points (On)**. See [Figure 2-6](#).
- Read the measurement results displayed on the screen.

Figure 2-6 N dB Bandwidth Measurement at -3 dB

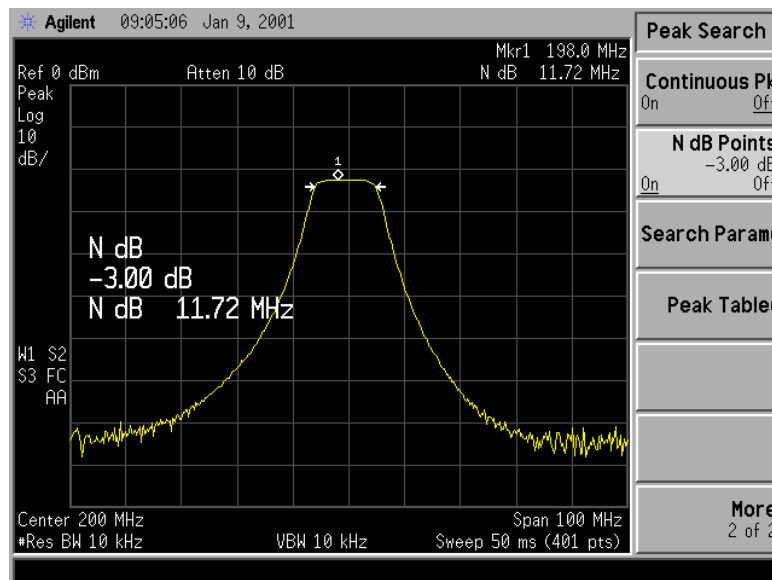

11. The knob or the data entry keys can be used to change the N dB value from -3 dB to -60 dB to measure the 60 dB bandwidth of the filter. See [Figure 2-7](#).

Figure 2-7 N dB Bandwidth Measurement at -60 dB

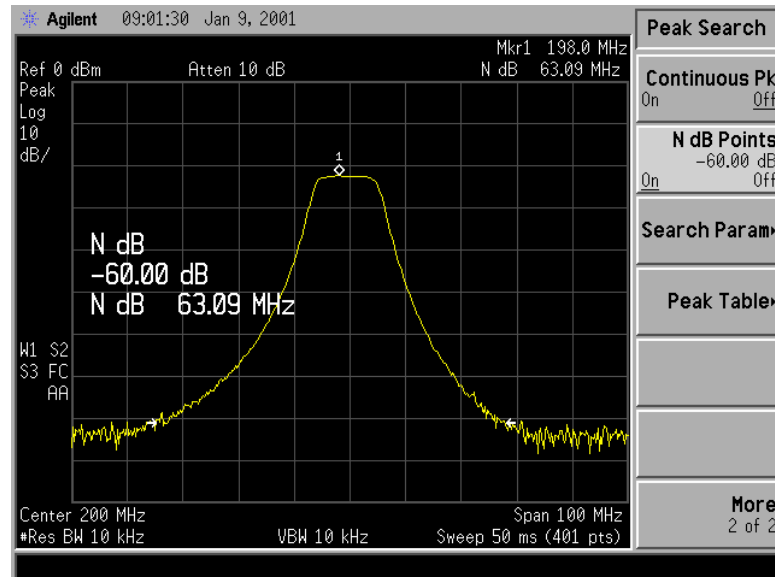

12. Press N dB Points (Off) to turn the measurement off.

Measuring Stop Band Attenuation Using Log Sweep

When measuring filter characteristics, it is useful to look at the stimulus response over a wide frequency range. Setting the analyzer x-axis (frequency) to display logarithmically provides this function.

Example:

Measure the stop band attenuation of a 10 MHz low pass filter.

1. To measure the response of a low pass filter, connect the equipment as shown in [Figure 2-8](#). This example uses a 10 MHz low pass filter.

Figure 2-8 **Transmission Measurement Test Setup**

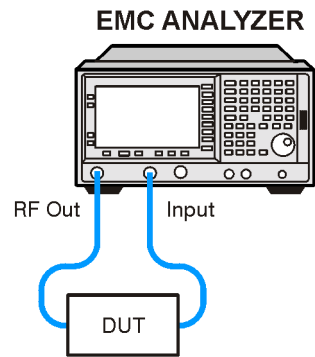

bb94a

2. Perform a factory preset by pressing **Preset, Factory Preset** (if present).
3. Set the Y-Axis Units to dBm by pressing **AMPLITUDE, More, Y-Axis Units, dBm**.
4. Set the start frequency to 100 kHz by pressing **FREQUENCY, Start Freq, 100, kHz**.
5. Set the stop frequency to 1 GHz by pressing **Stop Freq, 1, GHz**.
6. Set the resolution bandwidth to 10 kHz by pressing **BW/Avg, Res BW, 10, kHz**.
7. Set the frequency scale to log by pressing **FREQUENCY, Scale Type (Log)**.
8. For E7405A analyzers with Option UKB, set the input coupling to DC by pressing **Input, Coupling (DC)**.
9. Turn on the tracking generator and if necessary, set the output power to -10 dBm by pressing **Source, Amplitude (On), -10 , dBm**.

CAUTION

Excessive signal input may damage the DUT. Do not exceed the maximum power that the device under test can tolerate.

NOTE

To reduce ripples caused by source return loss, use 10 dB (E7401A) or 8 dB (all other models) or greater tracking generator output attenuation. Tracking generator output attenuation is normally a function of the source power selected. However, the output attenuation may be controlled in the **Source** menu. Refer to specifications and characteristics in your specifications guide for more information on the relationship between source power and source attenuation.

Figure 2-9 Tracking Generator Output Power Activated in Log Sweep

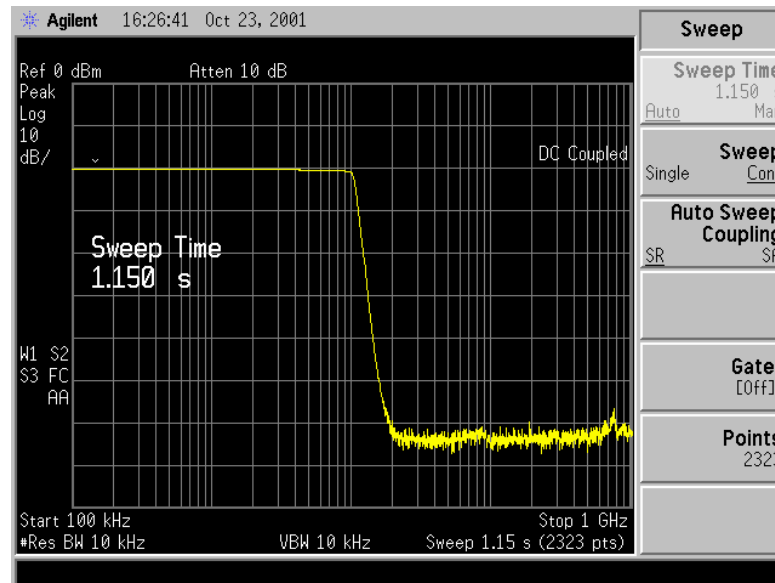

10. Put the sweep time of the analyzer into stimulus response auto coupled mode by pressing **Sweep**, then **Swp Coupling (SR)**. See [Figure 2-9](#). Auto coupled sweep times are usually much faster for stimulus response measurements than they are for spectrum analyzer (SA) measurements. Adjust the reference level if necessary to place the signal on screen.
11. To make a transmission measurement accurately, the frequency response of the test system must be known. Normalization is used to eliminate this error from the measurement. To measure the frequency response of the test system, connect the cable (but not the DUT) from the tracking generator output to the analyzer input. Press **Trace/View, More, Normalize, Store Ref (1→3), Normalize (On)**.

This will activate the trace 1 minus trace 3 function and display the results in trace 1. The normalized trace or flat line represents 0 dB return loss. Normalization occurs each sweep.

NOTE

Since the calibration trace is stored in trace 3, changing trace 3 to Clear Write, Max Hold, or Min Hold will invalidate the normalization.

12. Reconnect the DUT to the analyzer. Note that the units of the reference level have changed to dB, indicating that this is now a relative measurement. Refer to [Figure 2-10](#).
13. Press **Trace/View, More, Normalize, Norm Ref Posn** to change the normalized reference position. Arrowheads at the left and right edges of the graticule mark the normalized reference position. Using the knob results in a change in the position of the normalized trace, within the range of the graticule. Refer to [Figure 2-10](#).

Figure 2-10 Normalized Trace After Reconnecting DUT

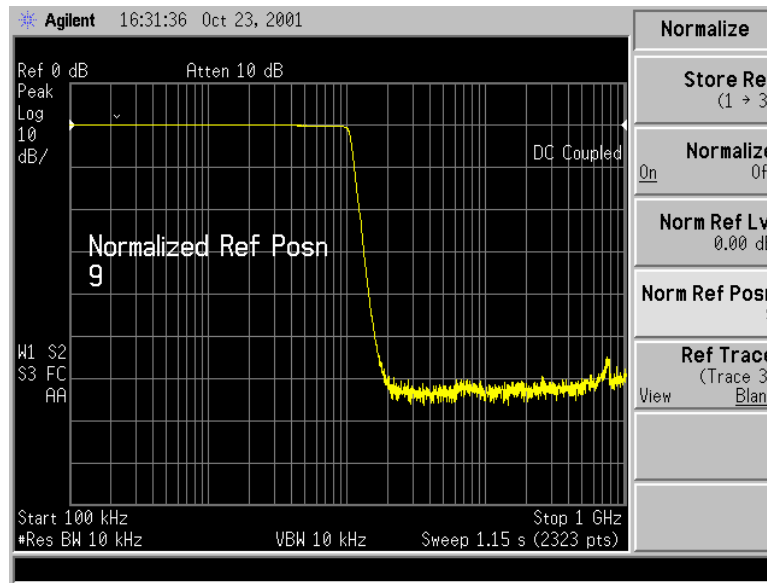

14. Press **Marker, Delta Pair (Ref), 10, MHz** to place the reference marker at the specified cutoff frequency.
15. Press **Delta Pair (Δ), 20, MHz** to place the second marker at the 20 MHz point. In this example, the attenuation over this frequency range is 63.32 dB/octave (one octave above the cutoff frequency).

Figure 2-11 Determining Low Pass Filter Rolloff

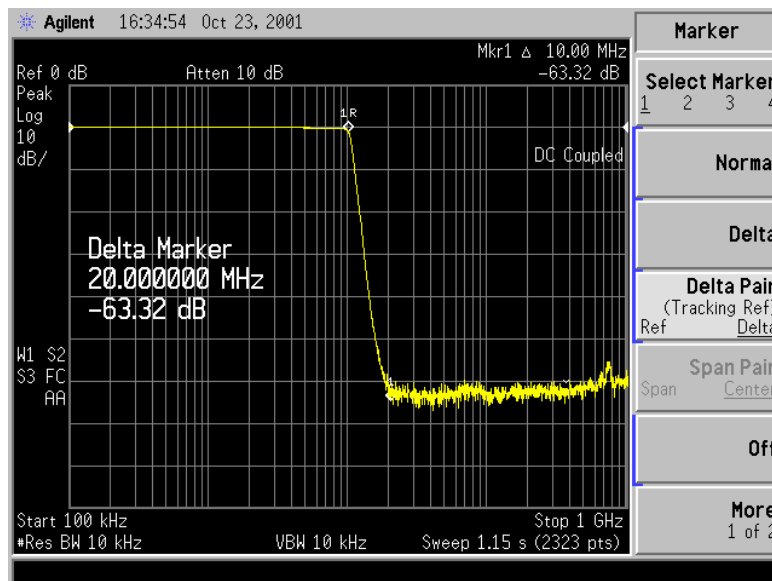

16. Use the knob to place the marker at the highest peak in the stop band to determine the minimum stop band attenuation. In this example, the peak occurs at 708.76 MHz. The attenuation is 54.92 dB.

Figure 2-12 Minimum Stop Band Attenuation

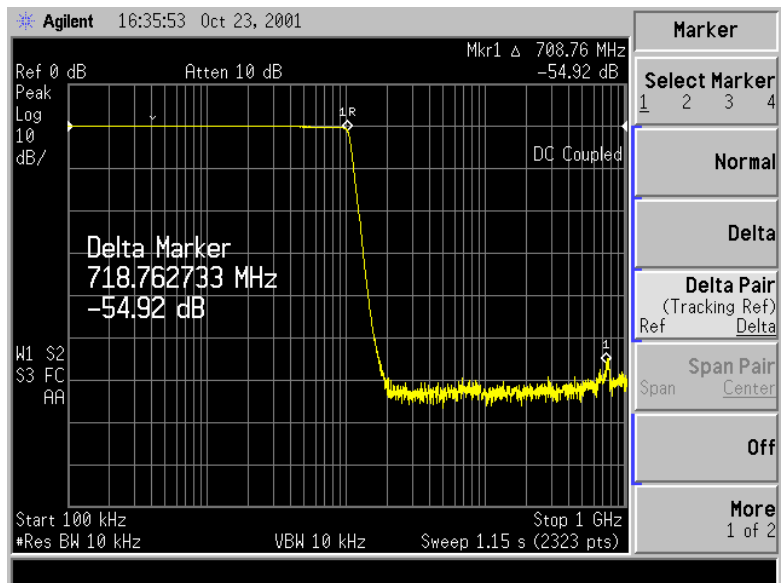

Making a Reflection Calibration Measurement

The calibration standard for reflection measurements is usually a short circuit connected at the reference plane (the point at which the device under test (DUT) will be connected.) See [Figure 2-13](#). A short circuit has a reflection coefficient of 1 (0 dB return loss). It reflects all incident power and provides a convenient 0 dB reference.

Figure 2-13 Reflection Measurement Short Calibration Test Setup

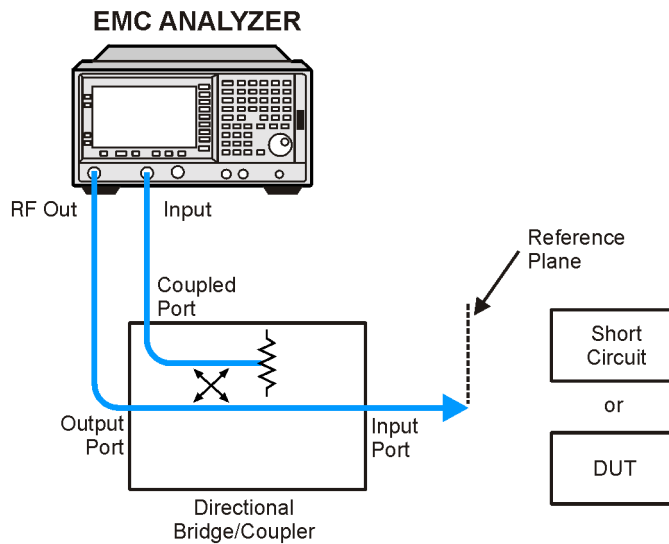

bb93a

Example:

Measure the return loss of a filter. The following procedure makes a reflection measurement using a coupler or directional bridge. This example uses a 200 MHz bandpass filter as the DUT.

NOTE

The analyzer center frequency and span for this measurement can easily be set up using the transmission measurement setup in [“Making Stimulus Response Measurements” on page 71](#). Tune the analyzer so that the passband of the filter comprises a majority of the display, then proceed with the steps outlined below.

Reflection Calibration

1. Connect the DUT to the directional bridge or coupler as shown in [Figure 2-13](#). Terminate the unconnected port of the DUT.

NOTE

If possible, use a coupler or bridge with the correct test port connector for both calibrating and measuring. Any adapter between the test port and DUT degrades coupler/bridge directivity and system source match. Ideally, you should use the same adapter for the calibration and the measurement. Be sure to terminate the second port of a two port device.

2. Connect the tracking generator output of the analyzer to the directional bridge or coupler.
3. Connect the analyzer input to the *coupled* port of the directional bridge or coupler.
4. Perform a factory preset by pressing **Preset, Factory Preset** (if present).
5. Set the Y-Axis Units to dBm by pressing **AMPLITUDE, More, Y-Axis Units, dBm**.
6. Turn on the tracking generator and if necessary, set the output power to -10 dBm by pressing **Source, Amplitude (On), -10 , dBm**.

CAUTION

Excessive signal input may damage the DUT. Do not exceed the maximum power that the device under test can tolerate.

7. Set the span to 100 MHz by pressing **SPAN, Span, 100, MHz**.
8. Set the center frequency to 200 MHz by pressing **FREQUENCY, Center Freq, 200, MHz**.
9. Set the resolution bandwidth to 3 MHz by pressing **BW/Avg, Res BW, 3, MHz**.
10. Replace the DUT with a short circuit.
11. Normalize the trace by pressing **Trace/View, More, Normalize, Store Ref (1→3), Normalize (On)**. See [Figure 2-14](#).

This will activate the trace 1 minus trace 3 function and display the results in trace 1. The normalized trace or flat line represents 0 dB return loss. Normalization occurs each sweep. Replace the short circuit with the DUT.

NOTE

Since the reference trace is stored in trace 3, changing trace 3 to Clear Write will invalidate the normalization.

Figure 2-14 Short Circuit Normalized

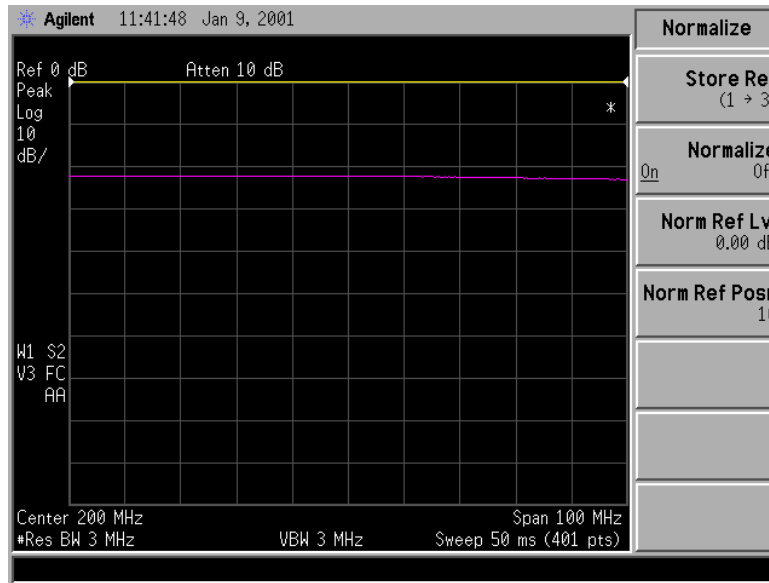

Measuring the Return Loss

1. After calibrating the system with the above procedure, reconnect the filter in place of the short circuit without changing any analyzer settings.
2. Use the marker to read return loss. Press **Marker** and position the marker with the knob to read the return loss at that frequency. Or you can use the Min Search function to measure return loss by pressing **Peak Search**, **Min Search**, the analyzer will place a marker at the point where the return loss is maximized. See [Figure 2-15](#).

Figure 2-15 Measuring the Return Loss of the Filter

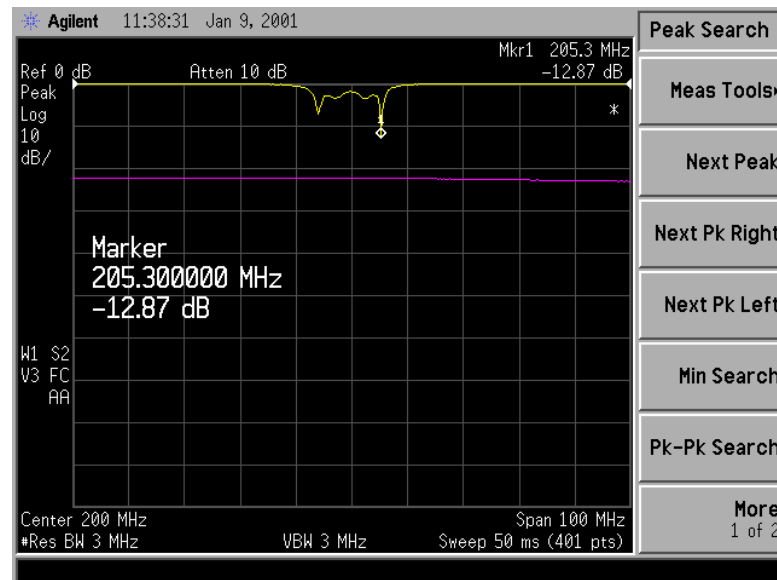

Converting Return Loss to VSWR

Return loss can be expressed as a voltage standing wave ratio (VSWR) value using the following table or formula:

Table 2-1 Power to VSWR Conversion

Return Loss (dB)	VSWR	Return Loss (dB)	VSWR	Return Loss (dB)	VSWR	Return Loss (dB)	VSWR	Return Loss (dB)	VSWR
4.0	4.42	14.0	1.50	18.0	1.29	28.0	1.08	38.0	1.03
6.0	3.01	14.2	1.48	18.5	1.27	28.5	1.08	38.5	1.02
8.0	2.32	14.4	1.47	19.0	1.25	29.0	1.07	39.0	1.02
10.0	1.92	14.6	1.46	19.5	1.24	29.5	1.07	39.5	1.02
10.5	1.85	14.8	1.44	20.0	1.22	30.0	1.07	40.0	1.02
11.0	1.78	15.0	1.43	20.5	1.21	30.5	1.06	40.5	1.02
11.2	1.76	15.2	1.42	21.0	1.20	31.0	1.06	41.0	1.02
11.4	1.74	15.4	1.41	21.5	1.18	31.5	1.05	41.5	1.02
11.6	1.71	15.6	1.40	22.0	1.17	32.0	1.05	42.0	1.02
11.8	1.69	15.8	1.39	22.5	1.16	32.5	1.05	42.5	1.02
12.0	1.67	16.0	1.38	23.0	1.15	33.0	1.05	43.0	1.01
12.2	1.65	16.2	1.37	23.5	1.14	33.5	1.04	43.5	1.01
12.4	1.63	16.4	1.36	24.0	1.13	34.0	1.04	44.0	1.01
12.6	1.61	16.6	1.35	24.5	1.13	34.5	1.04	44.5	1.01
12.8	1.59	16.8	1.34	25.0	1.12	35.0	1.04	45.0	1.01
13.0	1.58	17.0	1.33	25.5	1.11	35.5	1.03	45.5	1.01
13.2	1.56	17.2	1.32	26.0	1.11	36.0	1.03	46.0	1.01
13.4	1.54	17.4	1.31	26.5	1.10	36.5	1.03	46.5	1.01
13.6	1.53	17.6	1.30	27.0	1.09	37.0	1.03	47.0	1.01
13.8	1.51	17.8	1.30	27.5	1.09	37.5	1.03	47.5	1.01

$$VSWR = \frac{1 + 10^{\frac{-RL}{20}}}{1 - 10^{\frac{-RL}{20}}}$$

Where: RL is the measured return loss value.

VSWR is sometimes stated as a ratio. For example: 1.2:1 “one point two to one” VSWR. The first number is the VSWR value taken from the table or calculated using the formula. The second number is always 1.

Demodulating and Listening to an AM Signal

The functions listed in the menu under **Det/Demod** allow you to demodulate and hear signal information displayed on the analyzer. Simply place a marker on a signal of interest, activate AM demodulation, turn the speaker on, and then listen.

Demodulating and Listening to an AM Signal

Example 1:

1. Connect an antenna to the analyzer input.
2. Perform a factory preset by pressing **Preset**, **Factory Preset** (if present).
3. Set the Y-Axis Units to dBm by pressing **AMPLITUDE**, **More**, **Y-Axis Units**, **dBm**.
4. Select a frequency range on the analyzer, such as the range for AM radio broadcasts. For example, the frequency range for AM broadcasts in the United States is 550 kHz to 1650 kHz. Press **FREQUENCY**, **Start Freq**, **550, kHz**, **Stop Freq**, **1650, kHz**.
5. Place a marker on the signal of interest. Press **Peak Search** to place a marker on the highest amplitude signal, or press **Marker**, **Normal** and move the marker to a signal of interest. See [Figure 2-16](#).
6. Press **Det/Demod**, **Demod**, **AM**. Use the front-panel volume knob to control the speaker volume.

Figure 2-16 Demodulation of an AM Signal

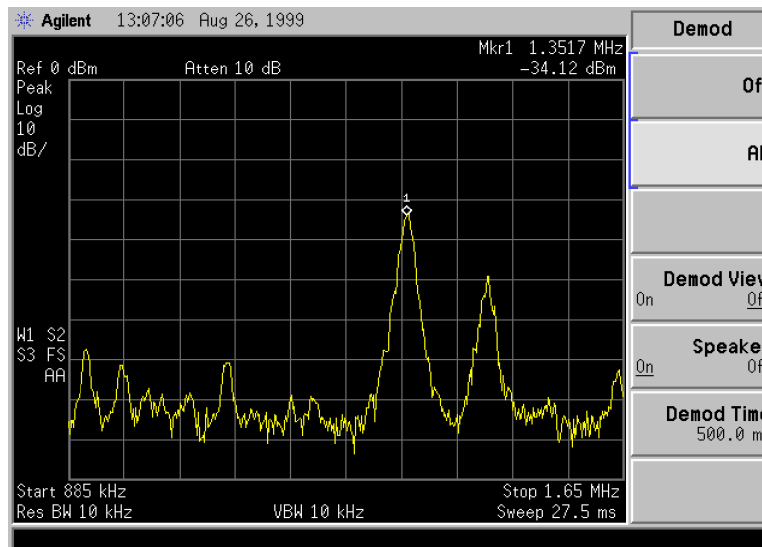

7. The signal is demodulated at the marker position only for the duration of the demod time. Use the step keys, knob, or numeric keypad to change the dwell time. For example, press the step up key (↑) to increase the dwell time to 2 seconds.
8. The marker search functions can be used to move the marker to other signals of interest. Press **Peak Search** to access **Next Peak**, **Next Pk Right**, or **Next Pk Left**.

Demodulating and Listening to an AM Signal Example 2:

1. Connect an antenna to the analyzer input.
2. Perform a factory preset by pressing **Preset**, **Factory Preset** (if present).
3. Select a frequency range on the analyzer, such as the range for AM radio broadcasts. For example, the frequency range for AM broadcasts in the United States is 550 kHz to 1650 kHz. Press **FREQUENCY**, **Start Freq**, **550**, **kHz**, **Stop Freq**, **1650**, **kHz**.
4. Place a marker on the signal of interest. Press **Peak Search** to place a marker on the highest amplitude signal, or press **Marker**, **Normal** and move the marker to a signal of interest.
5. Set the resolution bandwidth to spectrum analyzer by pressing **BW/Avg** and **Res BW (SA)**.
6. Set the frequency of the signal to center frequency by pressing **FREQUENCY** then **Signal Track (On)** if the signal of interest is the highest amplitude on screen signal. If it is not the highest amplitude signal on screen, move the signal to center screen by pressing **Peak Search**, **Marker→**, and **Mkr→CF**.
7. If the signal track function is on, press **SPAN**, **1**, **MHz** to reduce the span to 1 MHz. If signal track is not used, use the step down key (↓) to reduce the span and use **Mkr→CF** to keep the signal of interest at center screen.
8. Set the span to zero by pressing **SPAN**, **Zero Span**. **Zero Span** turns off the signal track function.
9. Change the resolution bandwidth to 100 kHz by pressing **BW/Avg**, **Res BW**, then enter **100**, **kHz**.
10. Set the signal in the top two divisions of the screen by changing the reference level. Press **AMPLITUDE**, and then the step down key (↓) until the signal is in the top two divisions. Set the amplitude scale to linear by pressing **Scale Type (Lin)**. Keep the signal center displayed by pressing **AMPLITUDE**, **Ref Level** and using the (↑) (↓) step keys.

11. Press **Det/Demod, Detector, Sample** to set the detector mode of the analyzer to **Sample**.
12. Press **Det/Demod, Demod, AM**. Use the front panel volume knob to control the speaker volume.
13. You can turn your analyzer into a % AM indicator as follows:
 - a. Set trigger to free run by pressing **Trig, Free Run**.
 - b. Set the sweep time to 5 seconds by pressing **Sweep, Sweep Time, 5, s**.
 - c. Set the video filter to 30 Hz by pressing **BW/Avg, Video BW, 30, Hz**.
 - d. Change the reference level to position the trace at midscreen by pressing **AMPLITUDE, Ref Level**, and adjust the reference level using the front-panel knob.
 - e. Reset the video filter to a high value. For example, press **BW/Avg, Video BW, 30, kHz**.
 - f. Set the sweep time to 5 milliseconds by pressing **Sweep, Sweep Time, 5, ms**.

The center horizontal line of the graticule now represents 0% AM; the top and bottom lines, 100% AM. See [Figure 2-17](#).
14. The signal to the speaker will be interrupted during retrace because the analyzer is performing automatic alignment routines. To eliminate the interruption and clicks between sweeps, turn the auto alignment function off by pressing **System, Alignments, Auto Align, Off**.

NOTE

Refer to the specifications for information about operating the analyzer with the alignments turned off.

Figure 2-17 Continuous Demodulation of an AM Signal

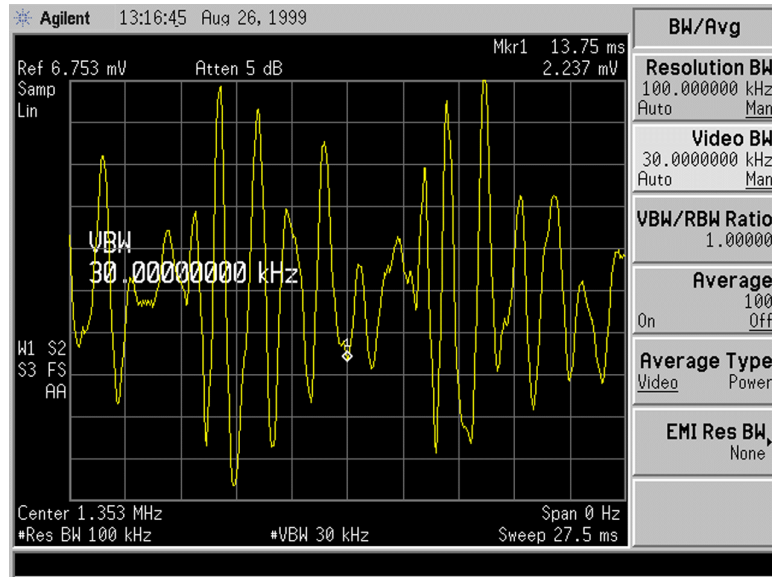

Making Complex Measurements
Demodulating and Listening to an AM Signal